

Doc. No.	W070226		WORK INSTRUCTION FOR	Dembla Valves Ltd.  THANE
Page No.	1 of 26			
	No	Date	V- Ball Valve Series - 8200 FV	
Issue	01	02.01.15		
Revision	00			

PREPARED BY		APPROVED BY	
SIGNATURE	Design Department	SIGNATURE	CTO
DATE	02.01.15	DATE	02.01.15



Dembla

## Instruction Manual

V-Ball Valve

Series-8200FV





Dembla

<b>CONTENTS</b>	<b>PAGE NO.</b>
<b>1.0 Foreword</b>	2
1.1 Scope of Instruction Manual	2
1.2 Copyrights and Modification Rights Reservation	2
1.3 Safety Instructions	2
<b>2.0 Storage &amp; Preservation</b>	3
<b>3.0 Valve Marking</b>	4
<b>4.0 Health &amp; Safety</b>	5
<b>5.0 Installation</b>	6
5.1 Pre-Installation Checks	6
5.2 Post Installation Checks	6
<b>6.0 Unpacking</b>	7
<b>7.0 Lifting Details</b>	8
<b>8.0 Maintenance</b>	10
<b>9.0 Replacing Gland Packing</b>	10
9.1 V-PTFE Packing	11
9.2 Double PTFE Packing	11
9.3 Grafoil Packing	12
9.4 Double Grafoil Packing	12
9.5 V-PTFE Low Fugitive Emission Packing	13
9.6 Grafoil Low Fugitive Emission Packing	13
<b>10.0 Replacing Seat Ring &amp; Body Seal</b>	14
<b>11.0 To Separate Actuator from Valve Body</b>	15
<b>12.0 Actuator Operation</b>	16
12.1 Manual Operation	17
<b>13.0 Actuator Maintenance</b>	17
13.1 Disassembly	18
13.2 Reassembly	19
13.3 Spring Return Actuator	20
13.3.1 Model PE	20
13.3.2 Model ES	21
<b>14.0 Parts Illustrated (for Rotary Actuator)</b>	22
<b>15.0 Parts Illustrated (V-Ball Valve with Rotary Actuator)</b>	23
<b>16.0 Torque for Studs</b>	24
<b>17.0 Recommended Spares</b>	24

## 1.0 Foreword

### 1.1 Scope Of Instruction Manual

This Instruction Manual covers information regarding Installation and Maintenance of Dembla's V-ball Valve Wafer Design with Rotary Actuator Series -8200FV.

### 1.2 Copyrights and Modification Rights Reservation

Dembla Valves Ltd. retains the Copyright on the contents of this Instruction Manual.

The total content of this Instruction Manual described here corresponds to the information during preparation of the Instruction Manual. It is user's responsibility to refer the latest version.

All data, specifications and illustrations here are subjected to Technical Modifications and improvements and hence Modification can be done by us at any time without any prior notice. No claim to Modification or repair of these Valves, which have already been supplied by us, can be made.

### 1.3 Safety Instructions

- 1) Before attending to Valve Installation / Maintenance, the Instruction Manual must be compulsorily read and understood properly.
- 2) Valve must be operated by qualified personnel.
- 3) Ensure that the operator handling these Valves must follow Safety and Accident Prevention Rules and Regulations.
- 4) Ensure that before opening the valve for maintenance or repair, wear suitable protection when dealing with hazardous process fluids.
- 5) All Safety Messages such as Cautions, Warnings and Notes are highlighted in this Instruction Manual which must be strictly followed to avoid any possibility of arising danger / risk of damage to the equipment / person's life.
- 6) No Liability on Manufacturer for any wrong handling, improper commissioning and wrong assembly.
- 7) No modification / conversions are allowed without written authorization from Dembla Valves Ltd.



Dembla

## 2.0 Storage & Preservation

All valves are dispatched in the closed/open position as ordered and it is recommended that they are left in this position during storage. All protective packing should remain in position until the valve is to be installed.

Valve should be stored in a clean and dry environment, without disturbing company setting. (e.g. gland, seat etc.) Protect it from shock & lifting damage.



If hoisting the valve, use a nylon sling to protect the surface. Carefully position the sling to prevent damage to Actuator tubing and any accessory. Also, take care to prevent people from being injured in case the hoist or rigging slips unexpectedly. For Valve Weight refer Valve Packing Slip.

### 3.0 Valve Marking

- 1) Valve name plate attached on Valve by riveting carrying all Valve Identification Information.
- 2) Markings like Valve Size, Rating, Material etc. are as cast on Valve Bodies.
- 3) Valve Serial no. punched on Valve Body Flange for Valve Traceability.
- 4) If the product is not CE marked, then name plate also without CE mark.

⊕

TAG No.

Sr. No.

SERIES

DNxRATING

TYPE

TRIM

BODY MOC

TRIM MOC

PS@TS bar(g)@°C

PS@TS bar(g)@°C

IMPACT °C

AIR TO

ACT. MODEL

STROKE

AIR SUPPLY

MONTH-YR

  
**Dembla**  
**INDIA**

⊕

### Name plate for Series:-8200 FV Valves

MAXIMUM OPERATING PRESSURE AT  
MAXIMUM OPERATING TEMPERATURE.

MAXIMUM OPERATING PRESSURE AT  
MINIMUM OPERATING TEMPERATURE.

IMPACT TEST TEMPERATURE

AIR TO OPEN/AIR TO CLOSE

VALVE TRAVEL



## 4.0 Health & Safety

- 1) Before attending to Valve Installation / Maintenance, the Instruction Manual must be compulsorily read and understood properly.
- 2) Valve must be operated by qualified personnel.
- 3) Ensure that the operator handling these Valves must follow Safety and Accident Prevention Rules and Regulations.
- 4) Follow the Safety Instructions before Installation, Maintenance or removing the Valve.
- 5) Always wear protective gloves, clothing and eyewear when performing any Installation operations to avoid personal injury.
- 6) All Safety Messages such as Cautions, Warnings and Notes are highlighted in this Instruction Manual which must be strictly followed to avoid any possibility of arising danger / risk of damage to the equipment/person's life
- 7) No Liability on Manufacturer for any wrong handling, improper commissioning and wrong assembly.
- 8) Line must be fully drained and de-pressurized before Installation or Maintenance of Valve.
- 9) Never handle Valves that have been used on harmful substances unless they have been completely decontaminated and certified safe to handle.
- 10) Due to the large physical size and weight of some size of this product, always use correct lifting methods and equipment when Installing , removing and Maintaining the product: Use lifting lugs on the body, wherever provided. Valve without lifting lugs-use chains or slings wrapped around the Body. Do not attempt to lift the Valve using the sealant fittings, gear unit, handwheel, Actuator, or the Valve Stem.
- 11) If the processes or environments that the products are used in are likely to cause temperature (high or low) that may cause injury to person if touched, then adequate insulation /protection must be fitted. It is recommended that the insulation allows easy access for Maintenance , to the sealant fittings , and to the Valve operator.
- 12) Valve must be protected from earthquake loading, traffic & wind.
- 13) No Modification / Conversions are allowed without written authorization from Dembla Valves Ltd.



## 5.0 Installation

### 5.1 Pre-Installation Checks:

Before installing any Control Valve

- Inspect it for any shipment damage and for foreign material that might have collected during packing and shipment.
- Blow out all pipelines to remove pipe scale-chips, welding-slag, and other foreign materials.
- Install the Valve using accepted piping practices. Use a suitable gasket between the Body and pipeline Flanges and tighten the Bolts evenly to avoid any strain on the body or cracking of Flange.
- Install the Control Valve preferably in a straight run of pipe away from bends or sections of abnormal velocity.
- Control Valves can be Installed in any orientation but the normal method is with the Actuator vertical.
- If continuous operation is required during maintenance and inspection, a conventional three way by-pass Valve should be Installed.
- An air supply pressure regulator with filter should be installed in the air line ahead of any instrument mounted on the Valves.
- Connect the Valve in pipe line with the standard connections.
- Valve should not be used for dead end service.

### 5.2 Post Installation Checks:

After the Valve has been Installed make a final check of following

- Vary air supply to the Actuator to ascertain that actual travel corresponds with the travel scale indication.
- Check all air lines to the Actuator for leaks.
- The Gland nuts are factory set, but should there be any Gland Leakage after Installation, further tightening, just enough to stop Gland Leak is recommended. Excessive tightening will disturb Stem movement.



Rise in temperature on surface of Valve Body depend on working media. End user must be maintaining the surface temperature & it should not go beyond temperature marked on Valve (Name Plate).



## 6.0 Unpacking

### For Carton

- Keep Carton in position (Carton up side should not be down).
- Cut plastic strip properly which is tied around Carton & remove it. (White in colour).
- Cut cello tape properly which is stuck on Carton opening.
- Open Carton properly.
- Remove foam properly along with polythene wrapping.
- Lift the Valve properly & keep on clean & dry place

### For Wooden Box

- Keep wooden Box in Position ('upside' of Wooden Box should not be 'down').
- Cut iron strip properly which is tied around Wooden Box & remove it.
- Remove the nail properly from Top Cover with proper equipment.
- Loosen and remove Valve fixing nut (from inside of Box).
- Lift the Valve properly as shown in figure 1



Dembla

## 7.0 Lifting Details

Valve should be lifted by using chain or bearer cables as shown in figure 1. (Take care that Valve should not damage while handling).

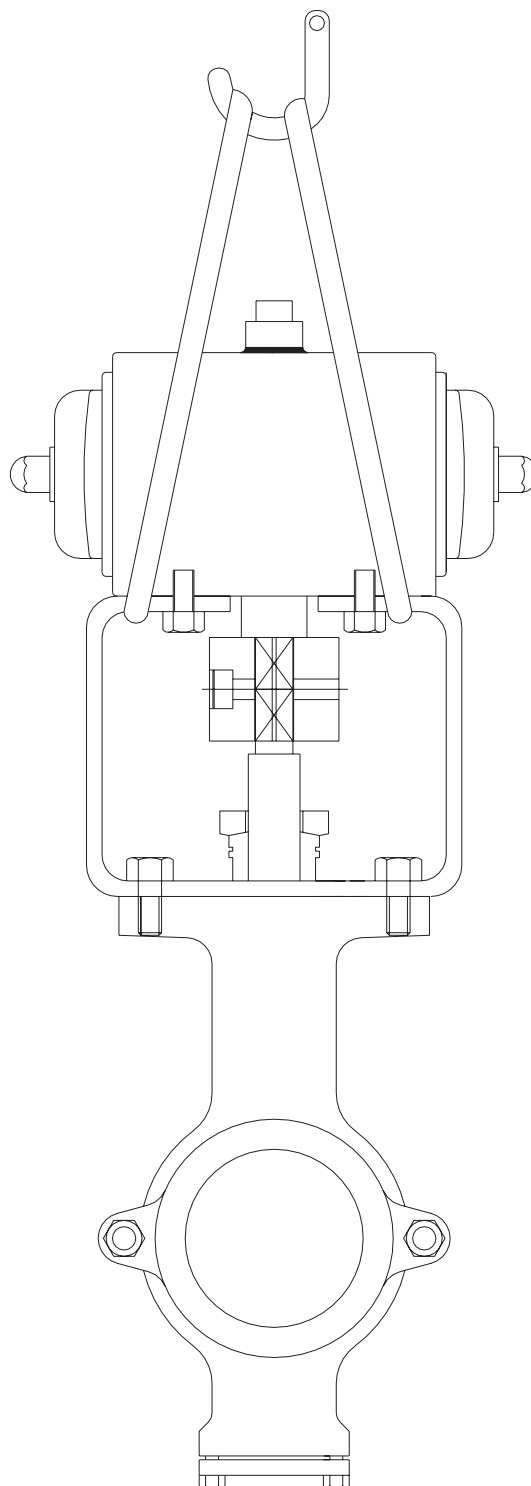

Fig. 1



Dembla

 **Warning**

- Always wear protective gloves, clothing, and eye ware when performing any Installation operation to avoid personal injury.
- Valve should be used by End-user with same pressure & temperature rating which was given in Valve marking (Name Plate). If there is any change please contact Dembla Sales Office.
- Avoid personal injury or property damage caused by components dropping .With the Valve or Actuator upside, components may drop during disassembly or assembly. Be careful not to position yourself below the valve in the path of falling parts.
- Personal injury could result from packing leakage. Valve packing was tightened prior to shipment, but should there be any Gland Leakage after Installation, further tightening, just enough to stop Gland leak is required. Excessive tightening will disturb Valve Calibration.
- Our Valves cannot be used for Defence, Nuclear, Telecommunication, Marine, Railway, and Laboratory & Mines.
- Our Valve is valid for atmospheres having pressure ranging for 0.8 bar to 1.1 bar and temperatures ranging for -20°C to +60°C.
- Earthing facility must be provided by end user before operating the Valve.
- Equipment should not be used for dead end service.

**After the Valve has been Installed, make a final check of the following :-**

- 1) An occasional cleaning of Valve Stem will prevent dirt or grit being carried away into the Packing.
- 2) Vary air lines and fitting to the Actuator to ascertain actual Travel Scale Indication.
- 3) check all air lines and fitting to the Valve Actuator & Accessories for air leaks.
- 4) Ensure that the combined action of Controller, Positioner and Valve provide the desired Valve Stem Movement. Also ensure the required fail safe position of Control Valve.

 **Caution**

- In case of leak, presence of high temperature may be dangerous to the person life.
- Equipment to be used as per intended and not misused / improperly used to avoid dangerous effects such as over load , overheating ,stress corrosion cracking, etc.

## 8.0 Maintenance

### **Warning**

- Avoid personal injury or damage to process system from sudden release of pressure of process fluid.
- Before starting dis-assembly use By-pass Valve or completely shut off the process to isolate the Valve from process pressure. Drain fluid from both ends of the Valve.
- Disconnect all operating lines providing air pressure, electric power or a control signal to the Actuator.
- Earthing facility and Valve parts should be checked periodically by the end user.
- Any Gasket once removed should be replaced by a new one upon re-assembly. This is necessary to ensure a good seal since the used Gasket may not seal properly.
- Equipment should be cleaned regularly.

## 9.0 Replacing Gland Packing

### **Warning**

Pipeline pressure is to be released before the Valve is to be opened for maintenance of Gland Packing, otherwise it may cause damage to the equipment / person's life.

Earthing facility and Valve parts should be checked periodically by end user.

- (1) Separate out operator from the Valve Body.
- (2) Remove the operator bracket from the Valve.
- (3) Unscrew and remove nuts on packing studs.
- (4) Remove Gland Flange, Gland Bush & Packing Spreader.
- (5) Take out Gland Packing from the Stuffing Box.

### **Caution**

Be careful while taking out Gland Bush, Gland Packing & Packing Spreader to avoid making scratches on the stuffing box wall.

- (6) Clean the Stuffing Box.
- (7) Follow the below procedure for the applicable Gland Packing option.

## 9.1 V-PTFE Packing

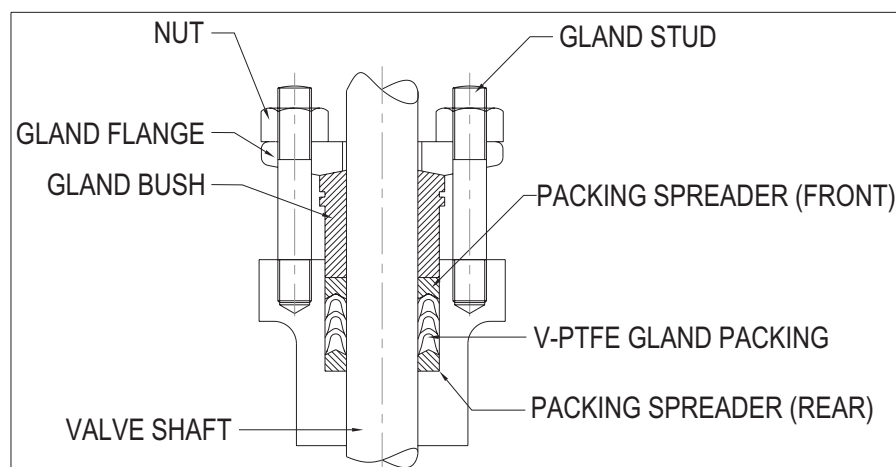

This Gland Packing consists of 1 Rear Packing Spreader, 1 set of V-PTFE Gland Packing and 1 Front Packing Spreader.

- (1) Place the V-PTFE Gland Packing set in the Body after 1 Rear Packing Spreader followed by Front Packing Spreader as shown in Fig. 9.1 Lubrication is not required.



**Caution**

**Push each V-PTFE Packing carefully inside to avoid the Packing lip to bend towards the outer side.**

- (2) Insert the Gland Bush.
- (3) Insert the Gland Flange on Gland Studs and tighten their Nuts to specified torque.

## 9.2 Double V-PTFE Packing

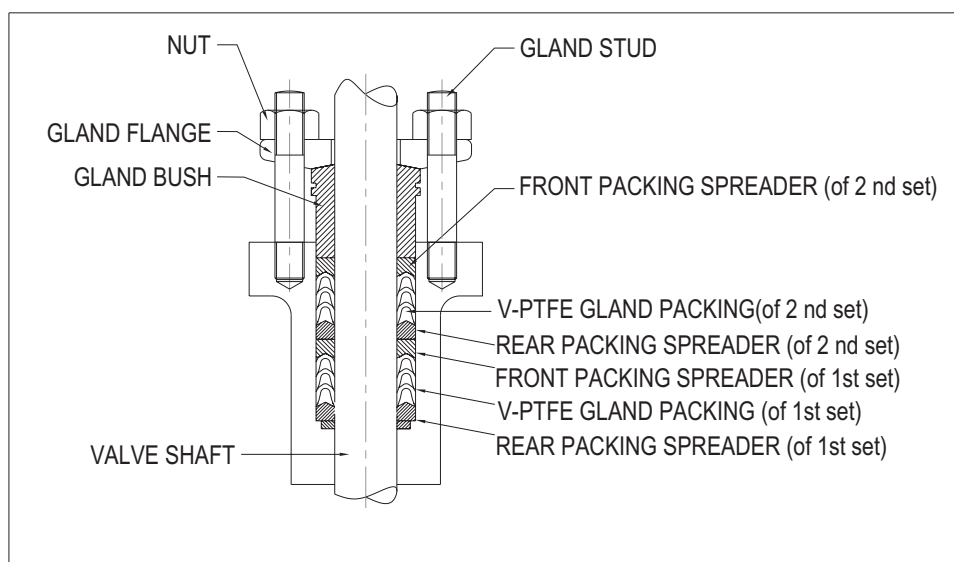

This Gland Packing consists of 1<sup>st</sup> set of Front and Rear Packing Spreader, 1<sup>st</sup> set of V-PTFE Gland Packing, 2<sup>nd</sup> set of Front and Rear Packing Spreader & 2<sup>nd</sup> set of V-PTFE Gland Packing.

- 1) Place the 1<sup>st</sup> set of V-PTFE Gland Packing after Rear Packing Spreader of 1<sup>st</sup> set followed by the Front Packing Spreader of 1<sup>st</sup> set.
- 2) On the Front Packing Spreader of 1<sup>st</sup> set place the 2<sup>nd</sup> set of V-PTFE Gland Packing after Rear Packing Spreader of 2<sup>nd</sup> set followed by the Front Packing Spreader of 2<sup>nd</sup> set.
- 3) Insert the Gland Bush.
- 4) Insert the Gland Flange on Gland Stud and tighten their Nuts to specified torque.

### 9.3 Grafoil Packing

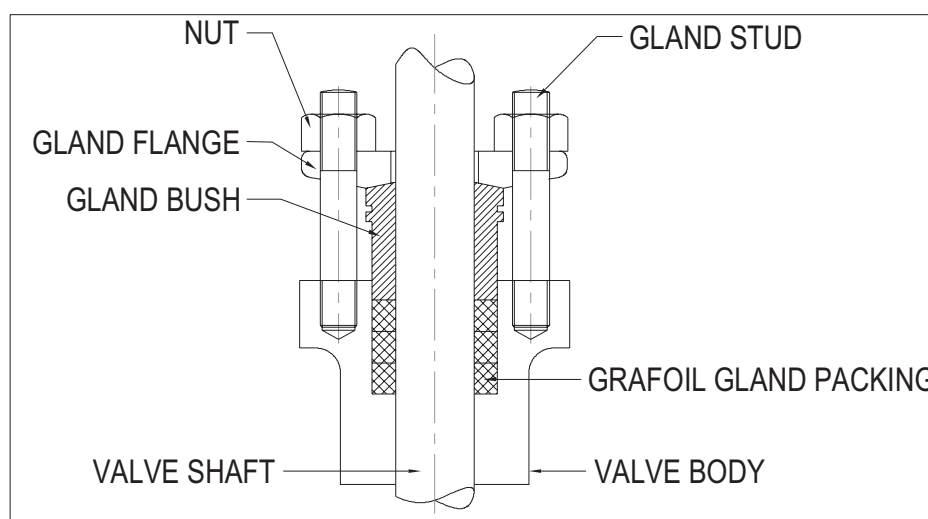

### 9.4 Double Grafoil Packing

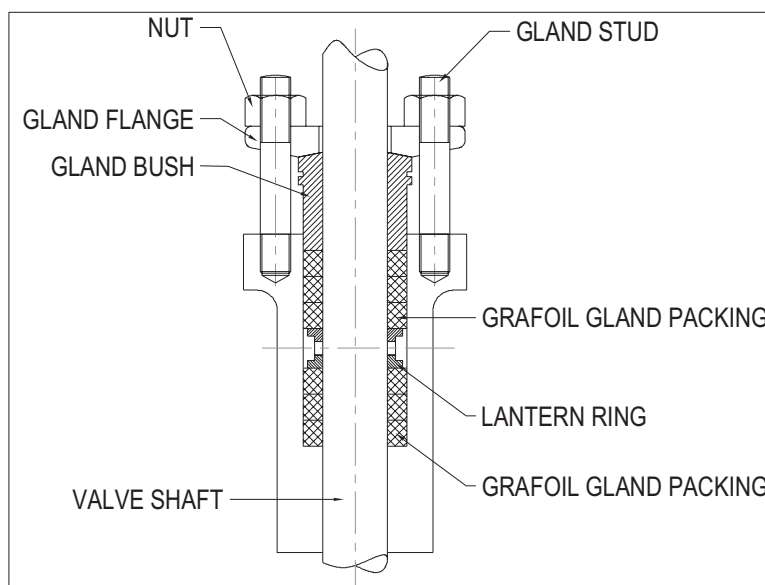

## 9.5 V-PTFE Low Fugitive Emission Packing

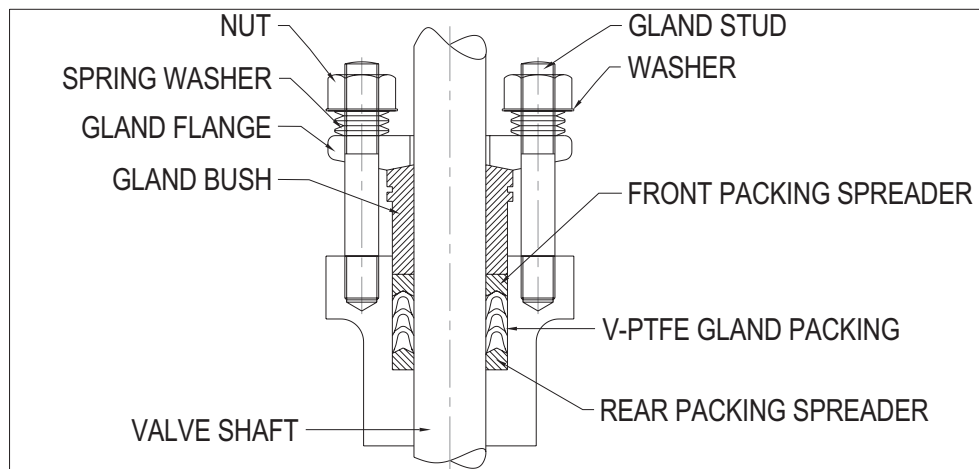

This Gland Packing consists of 1 Rear Packing Spreader, 1 set of V-PTFE Low Fugitive Emission Packing and 1 Front Packing Spreader.

- (1) Place the V-PTFE Low Fugitive Emission Packing set in the Body after 1 Rear Packing Spreader followed by Front Packing Spreader **as shown in Fig. 9.5 Lubrication** is not required.



**Caution**

**Push each V-PTFE Packing carefully inside to avoid the Packing lip to bend towards the outer side.**

- (2) Insert the Gland Bush.
- (3) Insert Gland Flange on Gland Studs.
- (4) Insert Spring washer on Gland Studs.
- (5) Insert Washer on Gland Studs.
- (6) Insert and tighten Gland nuts. (refer 9.5)

## 9.6 Grafoil Low Fugitive Emission Packing

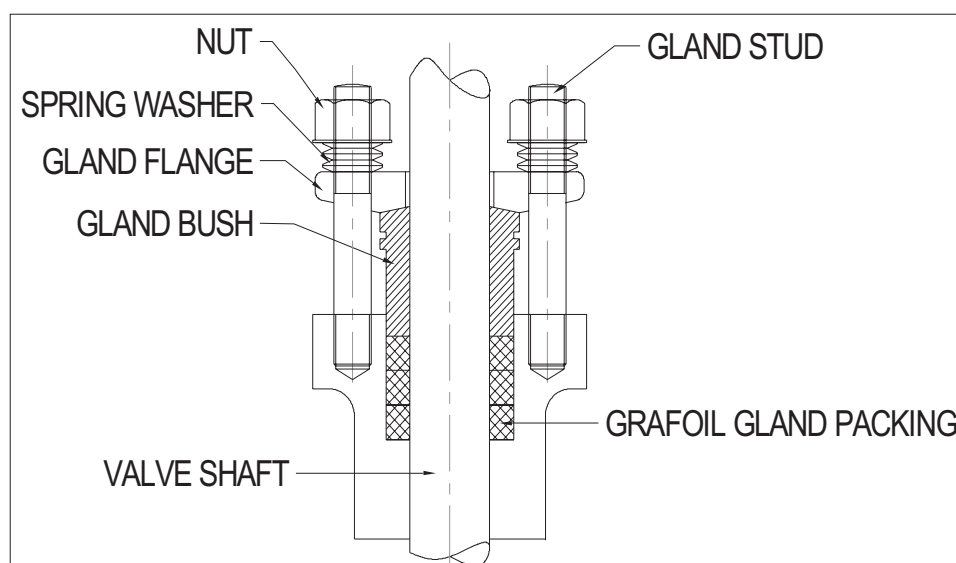

## 10.0 Replacing Seat Ring & Body Seal.

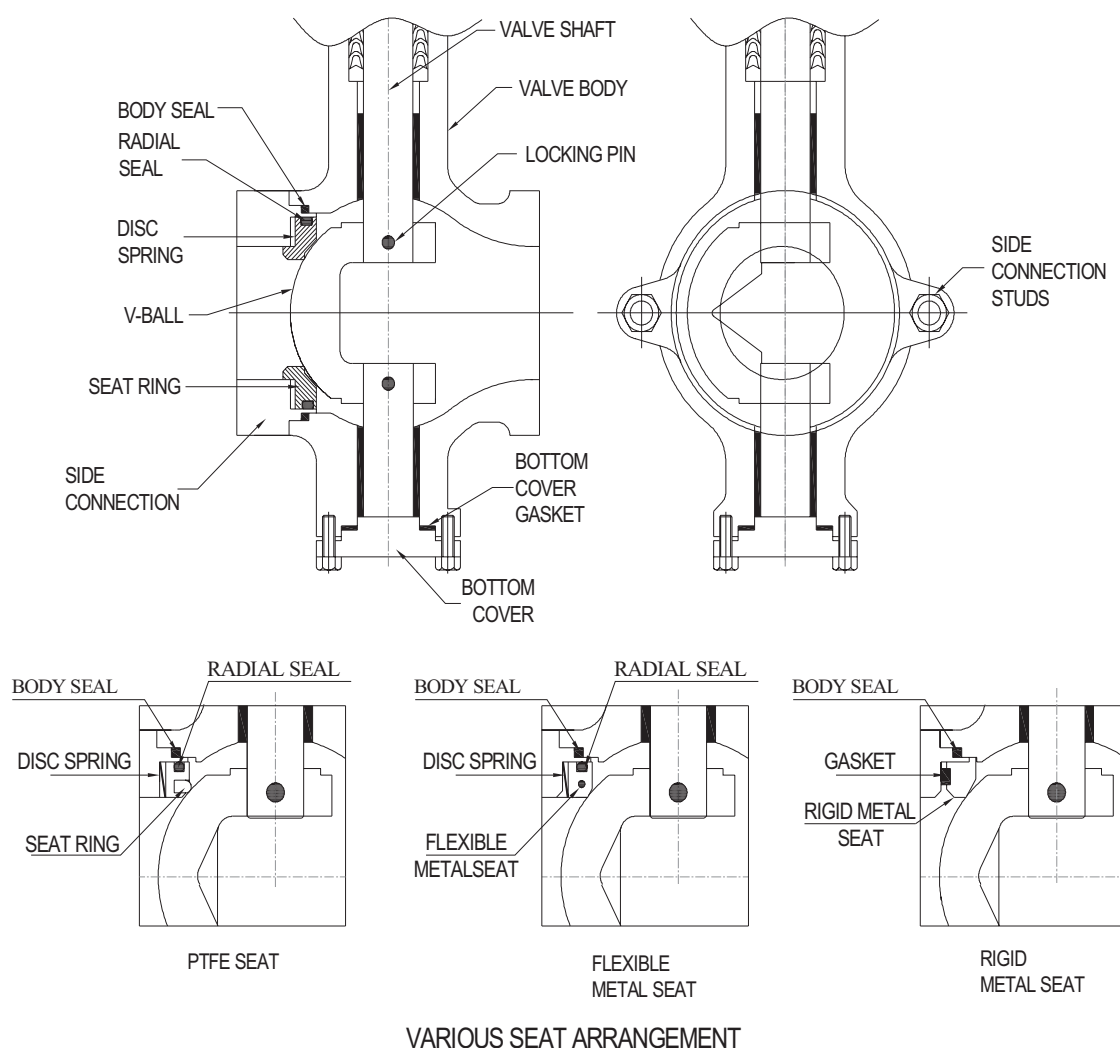

Fig. 2

**Note**

For the replacement of Seat Ring or Body Seal the Actuator or Valve Shaft need not be dismantled from the Valve Body.

- 1) Take out the Valve from the pipe line.
- 2) Loosen & remove Nuts on side connection Studs.
- 3) Take out the side connection from the Valve Body.
- 4) Remove Body Seal.
- 5) Remove Seat Ring and Disc Spring along with Radial Seal.
- 6) Replace the Body Seal, Seat Ring & Radial Seal as required & reassemble in reverse sequence.



## 11.0 To Separate Actuator from Valve Body.

### ⚠ Caution

#### Before starting disassembly.

- Use By-pass Valve or completely shut off the process to isolate the Valve from process pressure. Drain fluid from both ends of the Valve.
  - If the Valve opens with Pneumatic signal pressure to Actuator, remove air from the Actuator before attempting to remove Valve from line.
  - While dismantling the Valve, if any part is stuck up, do not use any pressure or force Technique. Use proven methods only.
- 1) Unscrew the Stem Connector Bolts & take out two halves of Stem Connector.
  - 2) Unscrew & remove the Actuator Mounting Bolts which connect the Actuator to the Mounting Bracket.
  - 3) Lift the Actuator along with Pinion Shaft & remove Pinion Shaft from Actuator.

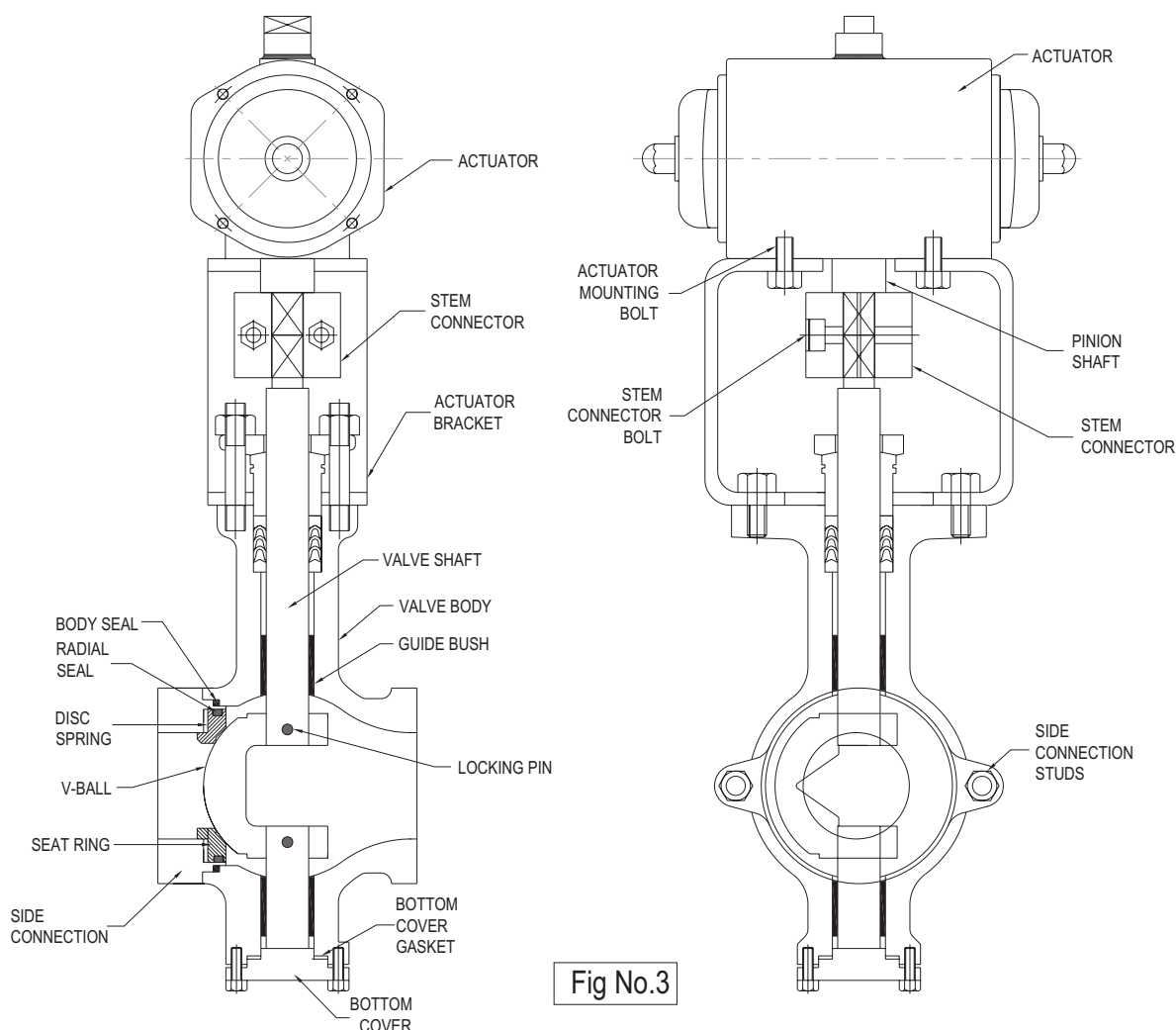

Fig No.3

## 12.0 Actuator Operation

The Actuator Drive Shaft rotates through a full 90°. Rotation is accomplished by feeding supply air into the center chamber (through Port A) forcing the two opposing Pistons outward, resulting in counter-clockwise rotation of the Drive Shaft to the 'Open' position. (Refer Fig. A)

For closure is accomplished by means of Springs contained in the end cap chambers, which force the Pistons inward when the supply air to the center chamber (Port A) is allowed to exhaust. (Refer Fig. A)

For double-acting Actuators, Rotation is accomplished by feeding supply air into the center chamber (through Port A) forcing the two opposing pistons outward, resulting in counter-clockwise rotation of the Drive Shaft to the 'Open' position, for closure is obtained by feeding supply air into the end cap chambers (through Port B) which forces the Pistons inward, resulting in clock-wise rotation of the Drive Shaft. (Refer Fig.B)

To reverse the stroke direction of the Actuator, remove both Pistons, rotate them by 180° and re-install. This will reverse the direction of rotation of the output shaft. (Refer Fig.C)

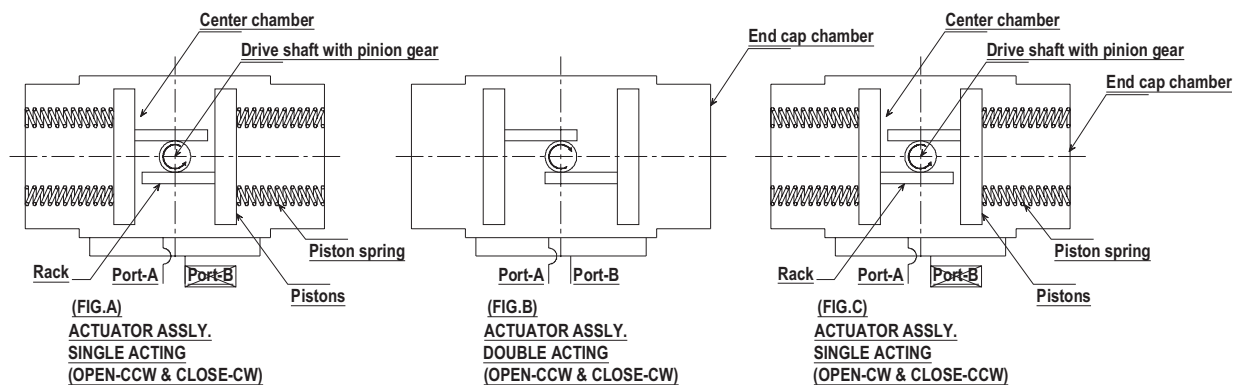

## 12.1 Manual Operation

In the event of air failure, the Actuator can be cycled manually. This is accomplished by applying a wrench to the exposed top shaft of the Actuator and turning it in the desired direction. This is not recommended on Model PD500/PE280 and larger size of Actuators. For these, Dembla offers optional Manual Over-ride Gear units, with declutch able hand wheels. (Not shown)

**CARE MUST BE TAKEN TO ENSURE THAT THE ACTUATOR IS NOT OPERATED AUTOMATICALLY THROUGH AIR SUPPLY WHILE MANUAL OPERATION IS BEING PERFORMED!**

Air must be allowed to exhaust from the Actuator for Manual Operation. For this disconnecting air lines or providing three-way vent Valves at inlet ports.

## 13.0 Actuator Maintenance

**THE ACTUATOR MUST BE ISOLATED BOTH PNEUMATICALLY AND ELECTRICALLY BEFORE ANY MAINTENANCE IS CARRIED OUT!**

All actuators are supplied with sufficient lubrication for their normal working life. If required, recommended lubrication for all standard Actuators is GREASE SERVOGEM 2.

Depending upon the conditions under which the Actuator must work such as extended duty, non-compatible operating media, or abnormal operating conditions, periodic replacement of internal seals is recommended. Repair kits containing all necessary seals can be obtained from DEMBLA.



Dembla

## 13.1 Disassembly (figure No.3)

**Before disassembling any Actuator be sure that a complete repair kit is available and that the kit has been checked for all parts.**

- 1) Disconnect the air supply and electrical service to the Actuator.
- 2) Remove accessories attached to Actuator.
- 3) Remove the Actuator from its mounting bracket by removing mounting bracket screw



**DISASSEMBLY AND REASSEMBLY OF THE ACTUATOR MUST BE DONE IN CLEAN, DUST FREE ENVIRONMENT!**

- 4) Each end cap is fitted into the Body with a set of end cap bolts. Remove all end cap bolts from both end caps by loosening them evenly. After the screws are removed, gently pry off each end cap taking due care not to damage the end cap O-Rings.

**IF THE ACTUATOR IS A 'SPRING RETURN' MODEL, UNIFORMLY LOOSEN ALL END CAPS SCREWS ON EACH END CAP TWO TO THREE TURNS AT A TIME, IN SEQUENCE, TO RELIEVE PRE-LOAD OF THE SPRINGS. ON ALL ACTUATORS WITH SPRINGS, USE CAUTION WHEN REMOVING END CAPS!**

- 5) The two Pistons can now be removed by rotating the Drive Shaft of Actuator, driving the Piston assembly outward until the Gear Rack and Pinions have disengaged.
- 6) Remove and discard circlip and the thrust washer from the Shaft.
- 7) Remove the Shaft through the bottom of the Body.
- 8) All O-Rings and bearings shall be Installed when all the Actuator surfaces are clean and free of grit and scratches. If the inside wall of the Body is scratched then, the Actuator will leak after reassembling. New clean & unscathed parts should be obtained from the factory.
- 9) Lubricate the standard Actuator thoroughly with grease. Apply a light film of grease to all O-Rings.

## 13.2 Reassembly

### Double Acting Actuator (figure No.3)

#### MODEL PD AND ED

- 1) Replace the top and bottom Shaft bearings.
- 2) Replace the Shaft in the Body through the bottom of each Actuator Body. The bottom hole in the Actuator Body is a larger in diameter than the top hole in the Body.
- 3) Very carefully align the Pistons with the rack to the Body.
- 4) Align the Pinion Gear so that the teeth on the Pinion Gear will 'pick up' the Pistons assemblies along with the rack teeth when turning the top extension of the Drive shaft clockwise (CW).
- 5) To ensure proper meshing of the teeth, rotate the center Gear 45° (or two teeth) counter clockwise (CCW) from its normal position with the Piston assemblies located at the Body ends. Normal positions are that position which provides the proper output Shaft orientation required.
- 6) With the Piston assemblies in the Body, gently push each Piston into the Body. Turn the top Shaft extension clockwise (CW). At the proper point of engagement between the center Gear and Piston assemblies, both Piston assemblies will move toward the center of the Body when turning top Shaft extension of the Actuator clockwise (CW).
- 7) Once the Pinion Gear and Pistons are properly engaged, ensure that smooth movement and 90° operations can occur without moving the Pistons out of the Actuator Body. This is important.
- 8) Replace the Actuator end caps taking care to properly seal O-Rings.
- 9) Replace the Washer over the top Shaft extension.
- 10) Install the new circlip into its mating groove on the top Shaft extension. (The removed shaft clip is not to be re-used!). When properly installed, the Shaft clip should rotate freely within the groove.



### 13.3 Spring Return Actuator

#### 13.3.1 MODEL PE

- 11) When replacing Spring return Actuator, ensure that the Springs are replaced in their identical position in the end cap from where they were removed. When less than the standard number of seven Springs are used in each end cap, these Springs should be positioned in balanced configuration
- 12) If a Spring return Actuator is being repaired due to a failed Spring, replace ALL the Springs in this Actuator, as well as any other parts which may have been damaged.
- 13) Replacing the Springs, place the Actuator Body on a clean, flat surface. Position it so that it stands on one end. Ensure that the Pistons are stroked fully inward toward the center of the Actuator. This may be done by rotating the Actuator Shaft with a wrench (external part).
- 14) Place the Springs on the Piston face, engaging them with the cast bosses into the Piston.
- 15) Place the end cap over the Springs. Align them with the corresponding bosses on the end cap.
- 16) Place the end cap over bolts through the retention holes of the end cap.

**IF CONVERTING A DOUBLE ACTING UNIT TO SPRING RETURN TYPE MAKE SURE TO USE NEW END CAPS.**

- 17) Engage the Bolts with the tapped holes in the Actuator Body by forcing down slightly on the cap. Tighten each Bolt in SMALL and EQUAL turns.

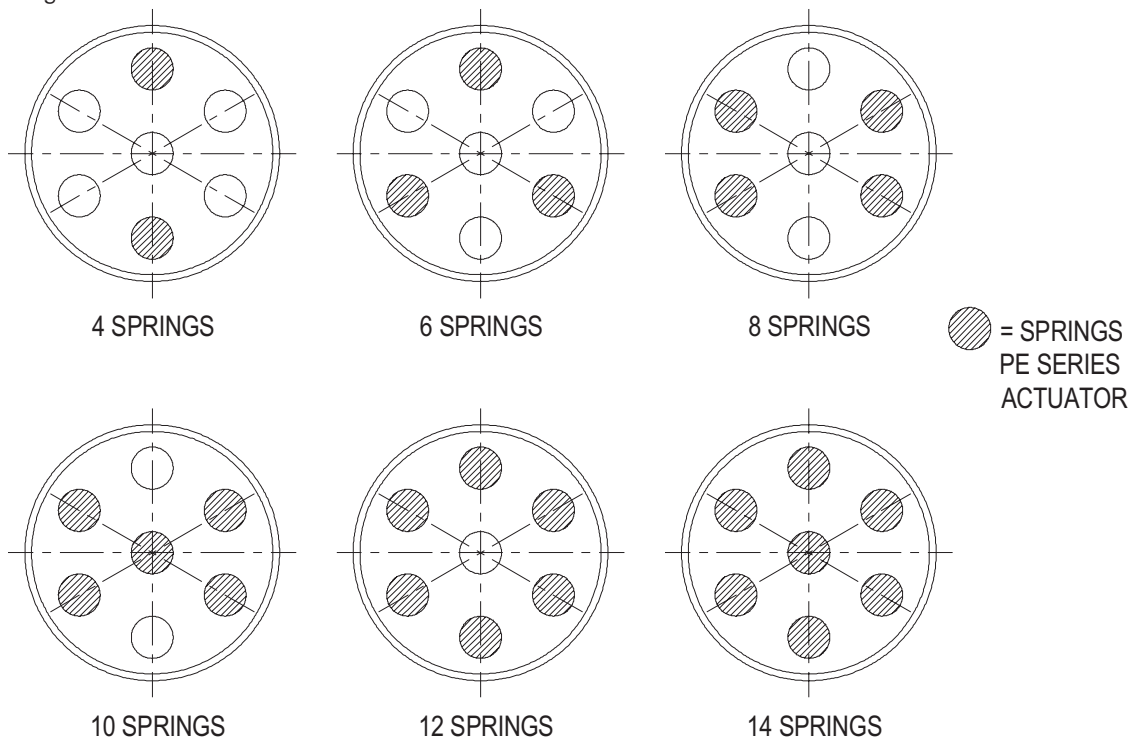

### 13.3.2 MODEL ES

- 18) When replacing ES springs in a spring return actuator, ensure that the springs are replaced in their identical positions in the spring pack from where they were removed.
- 19) If a spring return actuator is being repaired due to a failed spring, replace ALL springs in this Actuator, as well as any other parts which may have been damaged.
- 20) To change springs, open the end caps, remove nut cover, Locknut, Washer and O-ring.
- 21) Be sure that all springs are located correctly in the end cap and cast bosses into the Piston
- 22) Repeat steps 20 to 22 for the other spring pack.
- 23) Re-assemble in reverse order.

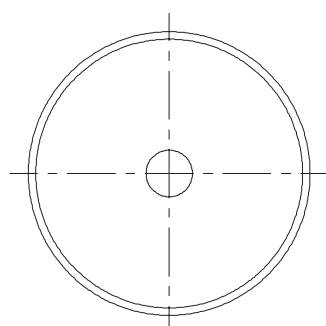

SPRING SET 1

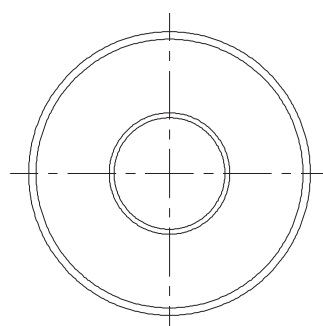

SPRING SET 2

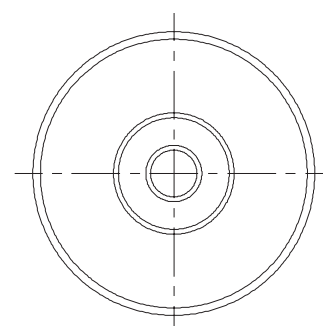

SPRING SET 3

 = SPRINGS  
ES SERIES  
ACTUATOR

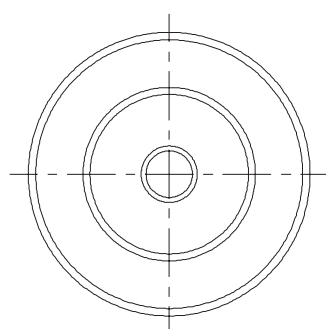

SPRING SET 4

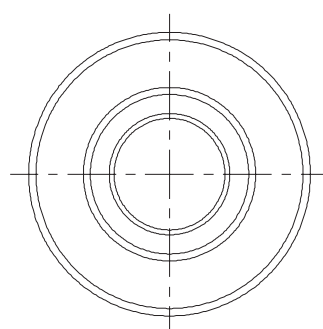

SPRING SET 5

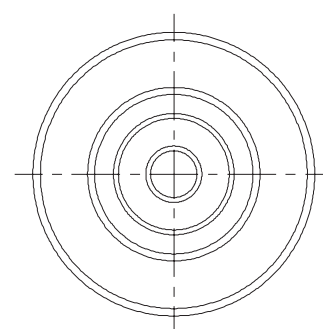

SPRING SET 6

### 14 .0 Parts Illustrated (for Rotary Actuator)

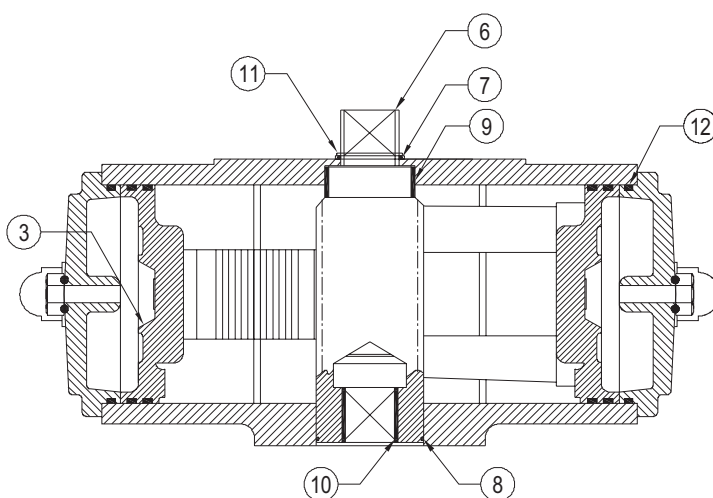

DOUBLE ACTING ACTUATOR

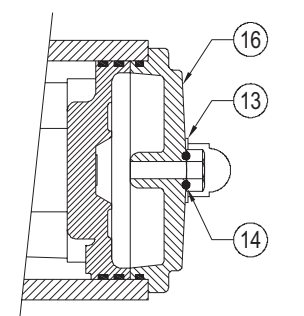

SINGLE ACTING ACTUATOR

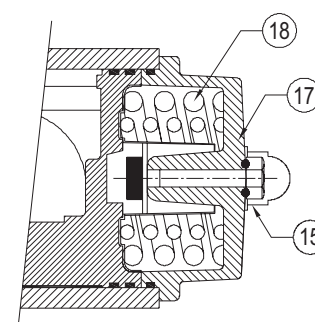
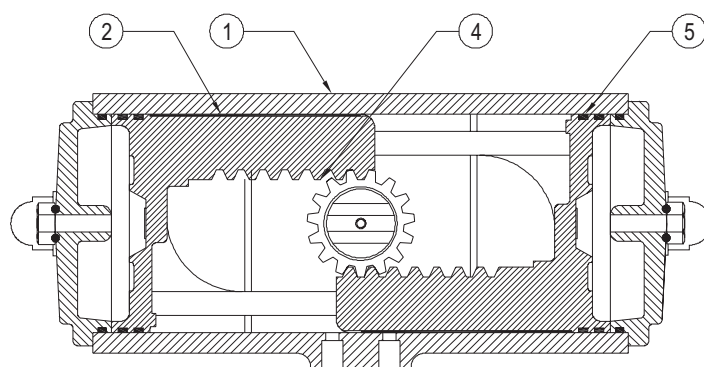

SR. NO.	DESCRIPTION	QTY	MATERIAL
1	BODY (HSG.)	1	ALUMINIUM ALLOY
2	GUIDE BAND (HSG.)	2	PTFE,CARBON FITTED
3	PISTON	2	ALUMINIUM ALLOY
4	GEAR RACK	2	STEEL
5	O-RING PISTON	2	NITRILE RUBBER
6	DRIVE SHAFT	1	STEEL
7	O-RING SHAFT TOP	1	NITRILE RUBBER
8	O-RING SHAFT BOTTOM	1	NITRILE RUBBER
9	BEARING BUSH TOP	1	DELRIN
10	BEARING BUSH BOTTOM	1	DELRIN
11	THRUST WASHER	1	DELRIN

SR. NO.	DESCRIPTION	QTY	MATERIAL
12	END CAP'O' RING	1	NITRILE RUBBER
13	WASHER	1	MS.
14	'O' RING	1	NITRILE RUBBER
15	NUT COVER	1	MS.
16	END CAP PD	2	ALUMINIUM ALLOY
17	END CAP PE	2	ALUMINIUM ALLOY
18	SPRING	2	STEEL



### 15.0 Parts Illustrated (V-ball Valve With Rotary Actuator)

No.	PART	QTY.
1	BODY	1
2	V-BALL	1
3	SEAT RING	1
4	RADIAL SEAL	1
5	BODY SEAL	1
6	SIDE CONNECTION	1
7	SIDE CONNECTING STUD	2
8	GUIDE BUSH	1
9	GLAND FLANGE.	1
10	GLAND STUD.	2
11	PACKING SPREADOR-FRONT	1
12	PACKING SPREADOR-REAR	1
13	GLAND PACKING.	1SET.
14	GUIDE BUSH.(BEARING)	1SET.
15	DISC LOCKING PIN.	2
16	GASKET- BODY TO BOTTOM COVER.	1
17	END COVER.	1
18	VALVE SHAFT	1SET.
19	ACTUATOR MOUNTING BRACKET	1
20	SHAFT CONNECTOR	1
21	ROTARY ACTUATOR	1

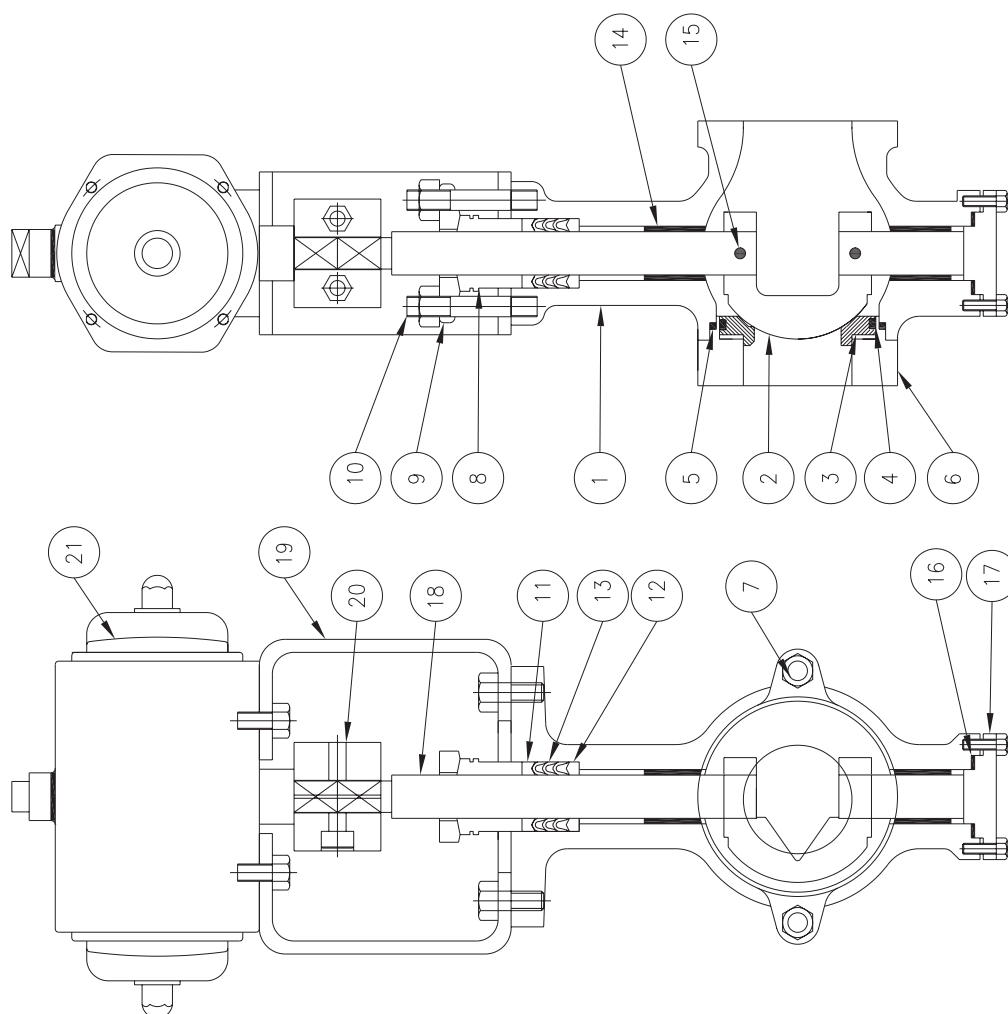



## 16.0 Torque For Studs

Studs	Torque Nm
5/16"	5
3/8"	7
1/2"	30
5/8"	50
3/4"	170

## 17.0 Recommended Spares

It is recommended to stock the following spares parts for commissioning and routine service.

Part No	Part Name	Recommended Quantity
203.15	Body Seal	One for every valve.
301/203.14	Seat Ring with Radial Seal	One for every five identical or one minimum.
302.20	V - Ball	One for every five identical or one minimum.
303.16	Valve Stem	One for every five identical or one minimum.
309	Gland Packing Set	One for every five identical or One minimum.
406	Actuator Springs Set	One for every five identical or One minimum.
411	Actuator Rubber Seal Kit	One for every five identical or One minimum.

### Note

Note: While ordering spares, please do not miss to indicate 'Valve Serial No.' Appearing on nameplate fixed on the actuator Valve Serial No. also appears on the Valve Body dully punched. The valve serial no. begins with prefix V, eg V - 12345.....

The contents of this publication are presented for informational purposes only, and while every effort has been made to ensure their accuracy. They are not to be construed as warranties or guarantees, express or implied, regarding the products or services described herein or their use or applicability. We reserve the right to modify or improve the designs or specifications of such products at any time without notice. Dembla does not assume responsibility for the selection, use or maintenance of any product. Responsibility for proper selection, use and maintenance of any Dembla product remains solely with the purchaser and end-user.

**Valve Disposal Detail :** After the complete use of valve. Dispose the valve with accessories as per your local laws.



**Dembla**

**Sales Office:**

M/S. Dembla Valves Ltd.  
C-30, Jai Matadi Compound, Kalher  
Village, Thane-Bhiwandi-Agra Raod -  
421302,  
Maharashtra, India.  
Tel - +91-9292234790 - 97  
E-mail - [expo@dembla.com](mailto:expo@dembla.com)  
[More info - www.dembla.com](http://www.dembla.com)

**Works:**

M/S. Dembla Valves Ltd.  
A/8, Arahm Logistic, Valshind Village,  
Mumbai -Nashik Highway  
(NH3), Bhiwandi  
Thane - 421302. Maharashtra (India)

