

Doc. No.	W070219		WORK INSTRUCTION FOR	Dembla Valves Ltd. THANE
Page No.	1 of 24			
	No	Date	Double Offset butterfly Valve Series- 7400	
Issue	01	02.01.15		
Revision	00			

PREPARED BY		APPROVED BY	
SIGNATURE	Design Department	SIGNATURE	CTO
DATE	02.01.15	DATE	02.01.15



Dembla

Instruction Manual

Double Offset Butterfly Valve

Series 7400





CONTENTS	PAGE NO.
1.0 Foreword	2
1.1 Introduction	2
1.2 Scope of Instruction Manual	2
1.3 Copyrights and Modification Rights Reservation	2
2.0 Storage & Preservation	2
3.0 Valve Marking	3
4.0 Health & Safety	4
5.0 Unpacking	5
6.0 Lifting Details	6
7.0 Installation of Butterfly Valve	8
7.1 Pre-Installation Checks	8
7.2 Operation	8
7.3 Lubrication	8
8.0 Maintenance	9
9.0 Replacing Gland Packing	9
9.1 V-PTFE Packing	10
9.2 Double V-PTFE Packing	10
9.3 Grafoil Packing	11
9.4 Double Grafoil Packing	11
9.5 V-PTFE Low Fugitive Emission Packing	12
9.6 Grafoil Low Fugitive Emission Packing	12
10.0 Replacing Soft Seat	13
10.1 Replacing Guide Bush (Bearings)	14
10.2 Trouble Shooting	15
11.0 Hand Lever Type Manual Operator	15
11.1 Operation	16
11.2 Removing Hand Lever Operator from the Valve Body	16
12.0 Gear Box Type Manual Operator	17
12.1 Operation	17
12.2 Setting of Gear Box Type Operator	18
13.0 Installation of Manual Operator	19
13.1 Fixing / Mounting Hand Lever on Body Set	19
13.2 Fixing / Mounting Gear Box Type operator on Body Set	19
14.0 Parts Illustrated	20
14.1 Butterfly Valve Assembly Flange: - Size 2" (50mm) to 6" (150mm)	20
14.2 Butterfly Valve Assembly Flange: - Size 8" (200mm) & 72" (1800mm)	21
15.0 Torque for Studs	22
16.0 Recommended Spare Parts	22

1.0 Foreword

1.1 Introduction

Dembla High Performance Butterfly Valves are available in Flange type Designs conforming to API 609 standard. The Disc construction is Double Offset. Shafts are guided by bearing. Various seat options are available.

1.2 Scope of Instruction Manual

This Instruction Manual covers information regarding Installation and Maintenance of Dembla's Double Offset High Performance Manual Butterfly Valves Flange type, Series 7400.

1.3 Copyrights and Modification Rights Reservation

Dembla Valves Ltd. retains the Copyright on the contents of this Instruction Manual.

The total content of this Instruction Manual described here corresponds to the information during preparation of the Instruction Manual. It is user's responsibility to refer the latest version.

All data, specifications and illustrations here are subjected to Technical Modifications and improvements and hence Modification can be done by us at any time without any prior notice. No claim to Modification or repair of these Valves, which have already been supplied by us, can be made.

2.0 Storage & Preservation

All Valves are dispatched in the closed/open position as ordered and it is recommended that they are left in this position during Storage. All protective Packing should remain in position until the Valve is to be Installed. Valve should be stored in a clean and dry environment, without disturbing company setting. (e.g. Gland, Seat etc.) Protect it from shock & lifting damage.



If hoisting the Valve, use a nylon sling to protect the surface. Carefully position the sling to prevent damage to Actuator tubing and any Accessory. Also, take care to prevent people from being injured in case the hoist or rigging slips unexpectedly. For Valve weight refer Valve Packing slip.



Dembla

3.0 Valve Marking

- 1) Valve name plate attached on Valve by riveting carrying all Valve Identification Information.
- 2) Markings like Valve Size, Rating, Material etc. are as cast on Valve Bodies.
- 3) Valve Serial No. punched on Valve Body Flange for Valve Traceability.
- 4) If the product is not CE marked, Then name plate is also without CE mark.

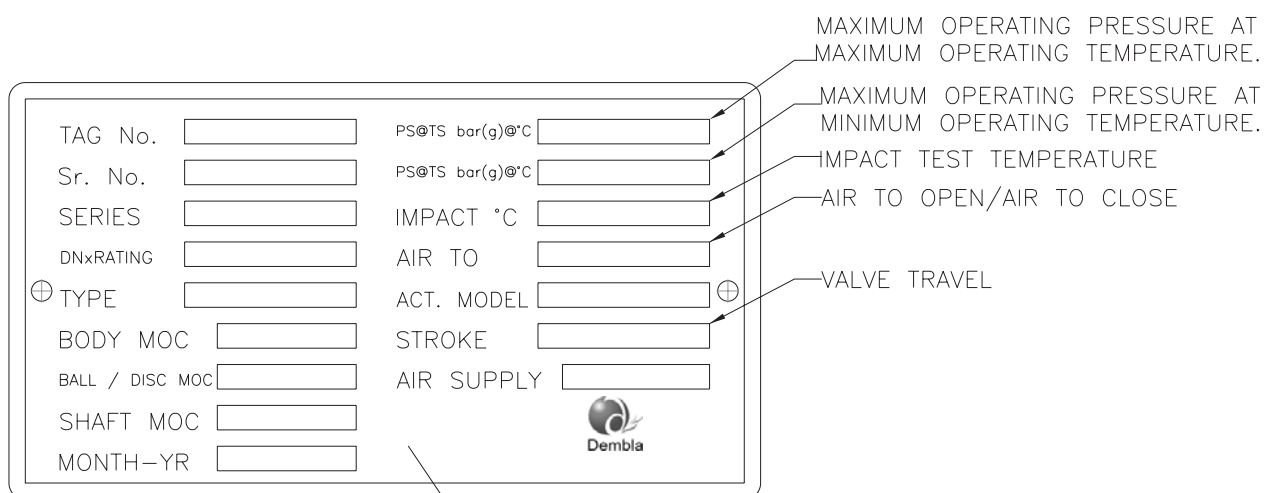

Name plate for Series:-7400 Valves



4.0 Health & Safety

- 1) Before attending to Valve Installation / Maintenance, the Instruction Manual must be compulsorily read and understood properly.
- 2) Valve must be operated by qualified personnel.
- 3) Ensure that the operator handling these Valves must follow Safety and Accident Prevention Rules and Regulations.
- 4) Follow the Safety Instructions before Installation, Maintenance or removing the Valve.
- 5) Always wear protective gloves, clothing and eyewear when performing any Installation operations to avoid personal injury.
- 6) All Safety Messages such as Cautions, Warnings and Notes are highlighted in this Instruction Manual which must be strictly followed to avoid any possibility of arising danger / risk of damage to the equipment/person's life
- 7) No Liability on Manufacturer for any wrong handling, improper commissioning and wrong assembly.
- 8) Line must be fully drained and de-pressurized before Installation or Maintenance of Valve.
- 9) Never handle Valves that have been used on harmful substances unless they have been completely decontaminated and certified safe to handle.
- 10) If the processes or environments that the products are used in are likely to cause temperature (high or low) that may cause injury to person if touched, then adequate insulation /protection must be fitted. It is recommended that the insulation allows easy access for Maintenance , to the sealant fittings , and to the Valve operator.
- 11) Valve must be protected from earthquake loading, traffic & wind.
- 12) No Modification / Conversions are allowed without written authorization from Dembla Valves Ltd.

5.0 Unpacking

For Carton

- Keep Carton in position (Carton 'up side' should not be 'down').
- Cut plastic strip properly which is tied around Carton & remove it. (White in colour).
- Cut cello tape properly which is stuck on Carton opening.
- Open Carton properly.
- Remove foam properly along with polythene wrapping.
- Lift the Valve properly & keep on clean & dry place

For Wooden Box

- Keep Wooden Box in Position ('upside' of Wooden Box should not be 'down').
- Cut iron strip properly which is tied around Wooden Box & remove it.
- Remove nail properly from top cover with proper equipment.
- Loosen and remove Valve fixing nut (from inside of Box).
- Lift the Valve properly as shown in figure 1

6.0 Lifting Details

Valve should be lifted by using chain or bearer cables as shown in figure 1. (Take care that Valve should not damage while handing).

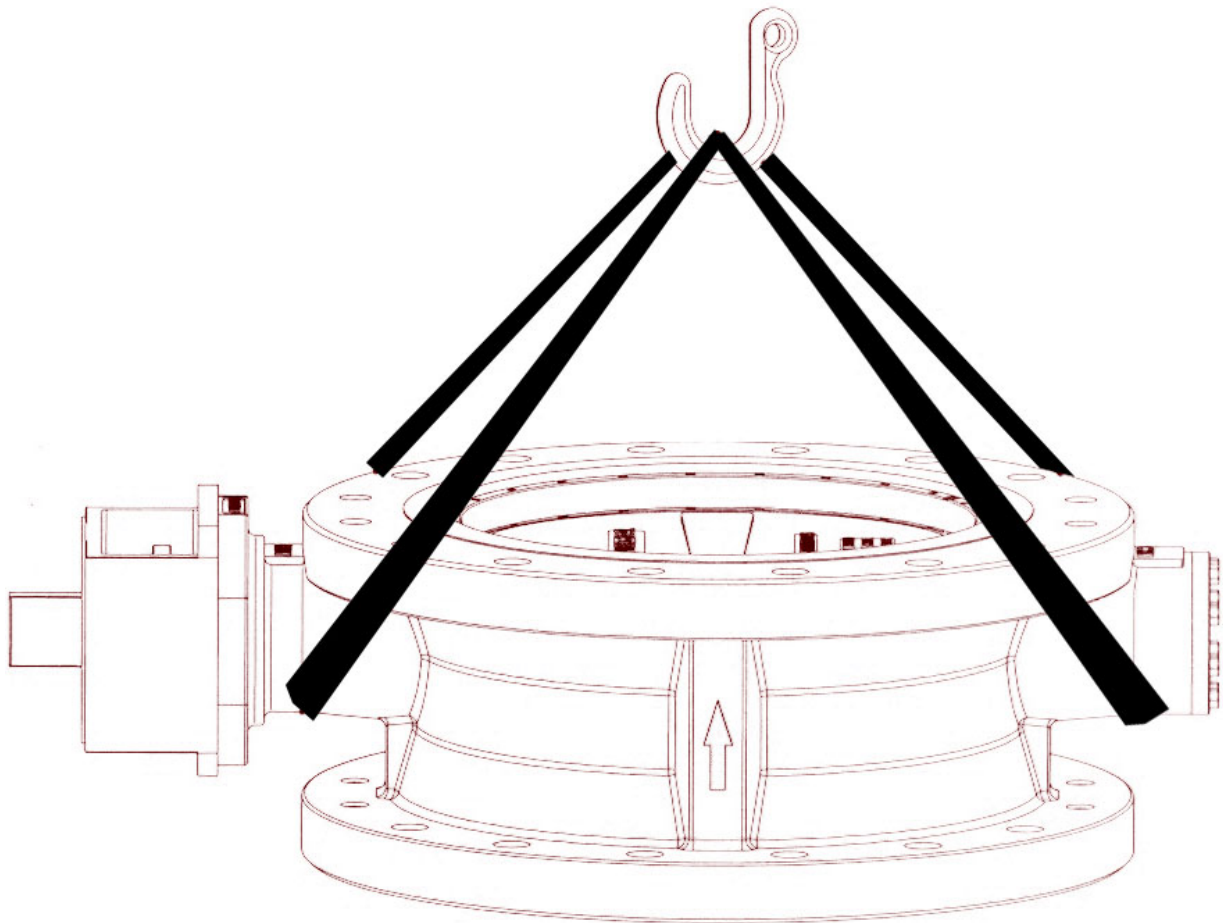

Fig .1



 **Warning**

- Always wear protective gloves, clothing, and eye ware when performing any Installation operation to avoid personal injury.
- Valve should be used by End-user with same pressure & temperature rating which was given in Valve Marking (Name Plate) If there is any change please contact Dembla Sales Office.
- Avoid personal injury or property damage caused by components dropping .With the Valve or Actuator upside, components may drop during disassembly or assembly. Be careful not to position yourself below the Valve in the path of falling parts.
- Personal injury could result from Packing Leakage. Valve Packing was tightened prior to shipment, but should there be any Gland Leakage after Installation, further tightening, just enough to stop Gland Leak is required. Excessive tightening will disturb Valve Calibration.
- Our Valves can not be used for Defence, Nuclear, Telecommunication, Marine, Railway and Laboratory & Mines.
- Our Valve is valid for atmospheres having pressure ranging for 0.8 bar to 1.1 bar and temperatures ranging for -20°C to +60°C
- Earthing facility must be provided by the end user before operating the Valve.
- Equipment should not be used for dead end service

After the Valve has been Installed, make a final check of the following :-

- 1) An occasional cleaning of Valve Stem will prevent dirt or grit being carried away into the Packing.
- 2) Vary air lines and fitting to the Actuator to ascertain actual Travel Scale Indication.
- 3) Check all air lines and fitting to the Valve Actuator & Accessories for air Leaks.
- 4) Ensure that the combined action of Controller, Positioner and Valve provide the desired Valve Stem Movement. Also ensure the required fail safe position of Control Valve.

 **Caution**

- In case of Leak, presence of high temperature may be dangerous to the person's life.
- Equipment to be used as per intended and not misused / improperly used to avoid dangerous effects such as over load ,over heating ,stress corrosion cracking, etc.

7.0 Installation of Butterfly Valve

7.1 Pre-Installation Checks: (Before Installing any Butterfly Valve)

- (1) Inspect it for any shipment damage and for foreign material that might have collected during Packing and shipment.
- (2) Blow out all pipelines to remove pipe scale-chips, welding-slag, and other foreign materials.
- (3) Install the Valve using accepted piping practices.
- (4) Install the Valve according to flow direction marked on the Valve.
- (5) Use self centering Gasket.
- (6) Install the Control Valve preferably in a straight run of pipe away from bends or sections of abnormal velocity.
- (7) Incorrect pipe alignment will cause interference between the disc edge and line Flange face, excessive torque and damage to disc and seat, resulting into Seat Leakage.
- (8) Do not try to Install Valve between line flanges having inadequate gap. This may cause damage to some Valve parts. If Valve is in fully open position, it will impact the Flanges and damage the disc edge.
- (9) No butterfly Valve should be attempted to Install when disc in open condition. The butterfly Valve can be inserted between line flanges in fully close position.
- (10) Glands are factory tightened and checked for Leakage however if there is any Gland Leak in Valves, the Gland may be further tightened just enough to stop Leakage. Excessive tightening should be avoided
- (11) Connect the Valve in pipe line with the standard connections.

7.2 Operation

Valve closes with clockwise rotation of the Valve Shaft. Valve is fully closed when disc is parallel to Seat Ring.

7.3 Lubrication

The Valve Body set does not require any routine lubrication. However Valve operator may require lubrication which is to be referred in the Part-II Manual Operator Section of this Instruction Manual.



8.0 Maintenance

- Avoid personal injury or damage to process system from sudden release of pressure of process fluid.
- Before starting dis-assembly Use by-pass Valve or completely shut off the process to isolate the Valve from process pressure. Drain fluid from both ends of the Valve.
- Disconnect all operating lines providing air pressure, electric power or a control signal to the actuator.
- Any Gasket once removed should be replaced by a new one upon re-assembly. This is necessary to ensure a good seal since the used Gasket may not seal properly.
- Earthing facility and Valve parts (Bush) should be checked periodically by the end user.
- Equipment should be cleaned regularly.

9.0 Replacing Gland Packing

- 1) Isolate the Control Valve from line pressure & release the pressure.
- 2) Removing Hand Lever Operator from the Valve Body in section 11.2 "Removing Actuator from the Valve Body.
- 3) Remove the Nuts from Body Studs on Bonnet and lift the Bonnet carefully off the Body. If the Valve Plug & Stem assembly starts to lift along with Bonnet, use a brass or Nylon hammer on the end of the stem & tap it back down.



Caution

Set the Bonnet on a protective surface to prevent damage to the Bonnet Gasket surface.

- 4) Remove the Valve Plug & Stem assembly from the Body.
Handle the Plug & Stem carefully to avoid the damage at seating surface of & Stem diameter.
- 5) Unscrew and remove Gland Flange Nut.
- 6) Remove Gland Flange.
- 7) Push out Gland Packing from the Bonnets bottom side Gland Packing & Spreader carefully take out by using a rounded rod or other tool that will not scratch but clean the stuffing box wall.
- 8) Install Plug & Stem assembly. Then slide the Bonnet over the stem and on to the Body Studs.
- 9) Install new Packing Seal & Metal Gland Parts according to the appropriate arrangement.
- 10) Lubricate the Body Studs and Install the nuts. Use accepted bolting procedure during tightening so that the Body to bonnet joint will with stand test pressures and application service condition, before tightening nuts make sure that Plug & Stem assembly is properly aligned with Seat Ring.
- 11) For the Installation of Gland Packing refer following 9.1 to 9.6
- 12) Mount the Actuator & Connect Stem Connector as specified in the "Reassembly of Actuator on Valve Body" Refer Section 11.0 of this Manual.

9.1 V-PTFE Packing

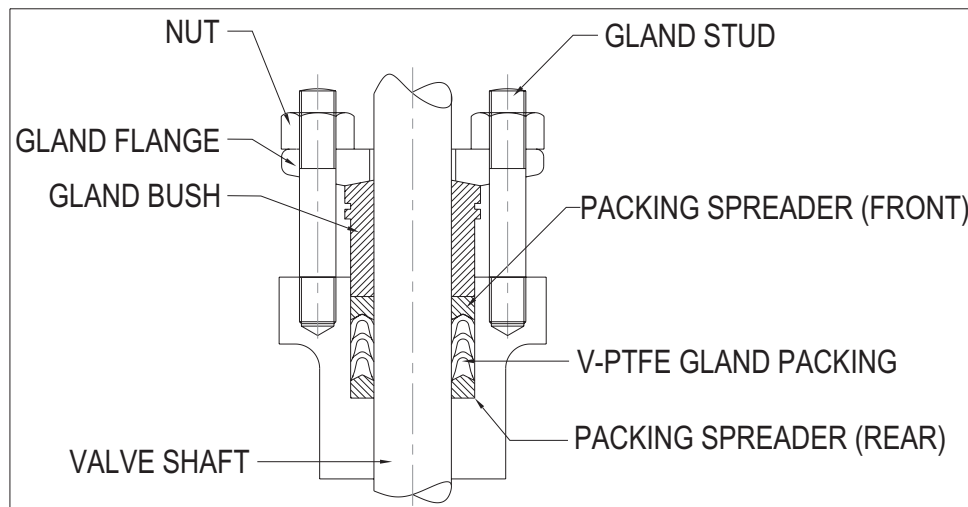

This Gland Packing consists of 1 Rear Packing Spreader, 1 set of V-PTFE Gland Packing and 1 Front Packing Spreader.

- (1) Place the V-PTFE Gland Packing set in the Body after 1 Rear Packing Spreader followed by Front Packing Spreader as shown in Fig. 9.1 Lubrication is not required.



Push each V-PTFE Packing carefully inside to avoid the Packing lip to bend towards the outer side.

- (2) Insert the Gland Bush.
- (3) Insert the Gland Flange on Gland Studs and tighten their Nuts to specified torque.

9.2 Double V-PTFE Packing

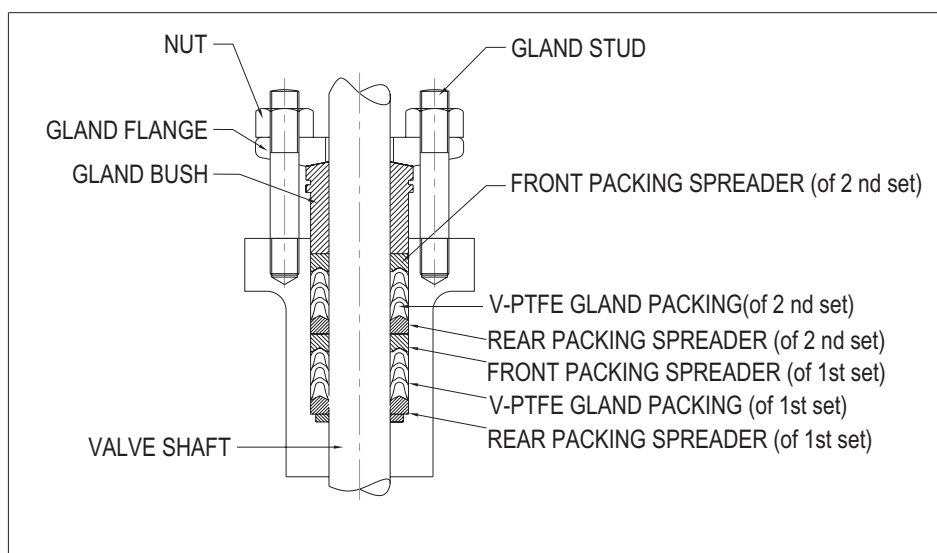

This Gland Packing consists of 1st set of Front and Rear Packing Spreader, 1st set of V-PTFE Gland Packing, 2nd set of Front and Rear Packing Spreader & 2nd set of V-PTFE Gland Packing.

- 1) Place the 1st set of V-PTFE Gland Packing after Rear Packing Spreader of 1st set followed by the Front Packing Spreader of 1st set.
- 2) On the Front Packing Spreader of 1st set place the 2nd set of V-PTFE Gland Packing after Rear Packing Spreader of 2nd set followed by the Front Packing Spreader of 2nd set.
- 3) Insert the Gland Bush.
- 4) Insert the Gland Flange on Gland Stud and tighten their Nuts to specified torque.

9.3 Grafoil Packing

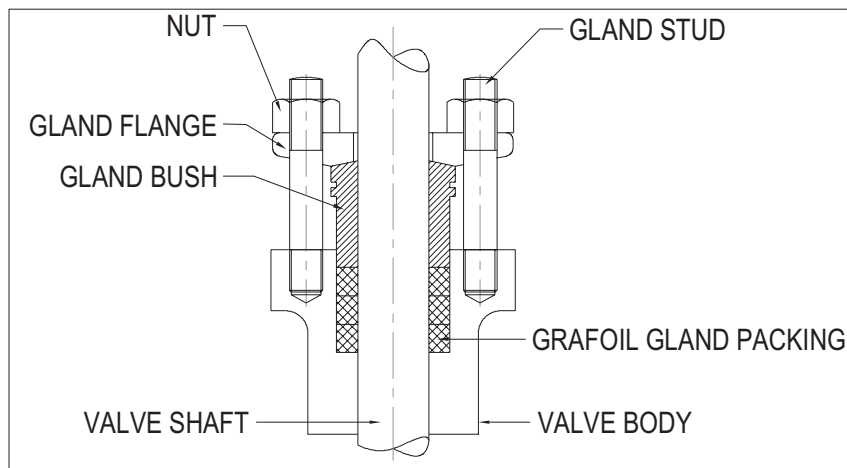

9.4 Double Grafoil Packing

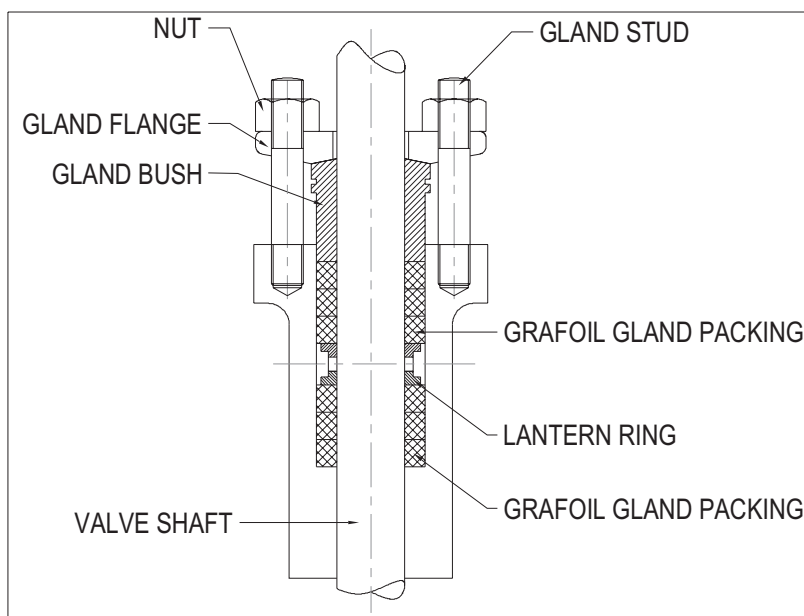

9.5 V-PTFE Low Fugitive Emission Packing

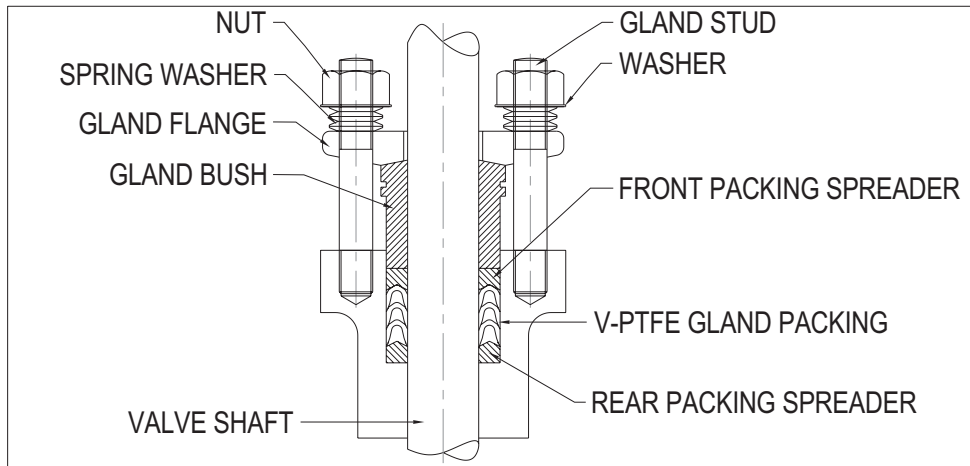

This Gland Packing consists of 1 Rear Packing Spreader, 1 set of V-PTFE Low Fugitive Emission Packing and 1 Front Packing Spreader.

- (1) Place the V-PTFE Low Fugitive Emission Packing set in the Body after 1 Rear Packing Spreader followed by Front Packing Spreader as shown in Fig. 9.5 Lubrication is not required.



Caution

Push each V-PTFE Packing carefully inside to avoid the Packing lip to bend towards the outer side.

- (2) Insert the Gland Bush.
- (3) Insert Gland Flange on Gland Studs.
- (4) Insert Spring washer on Gland Studs.
- (5) Insert Washer on Gland Studs.
- (6) Insert and tighten Gland nuts. (refer 9.5)

9.6 Grafoil Low Fugitive Emission Packing

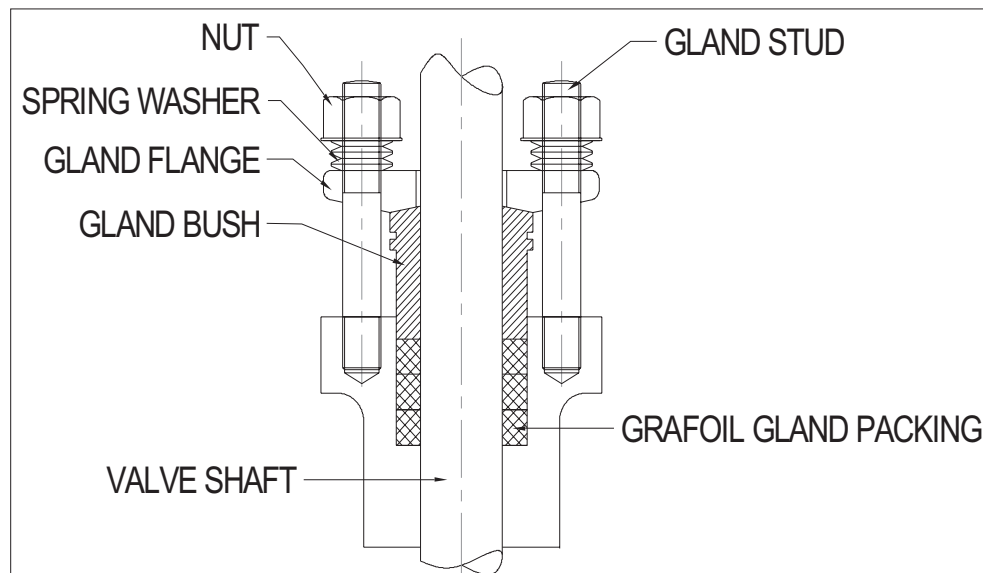

10.0 Replacing Soft Seat.

Note

For maintenance or replacement of Soft Seat, operator and bracket need not be dismantled.

- (1) Isolate the Control Valve from line pressure and release the pressure.
- (2) Remove the complete Valve from the pipe line.
- (3) Unscrew and remove the Seat Retainer screws.
- (4) Take out the Seat Retainer.
- (5) Take out Soft Seat.
- (6) Replace the Soft Seat with new one and reinstall the Seat Retainer.

Note

- Soft Seat must be replaced once it is dismantled.
- Soft Seat should be Installed preferably with the Valve in close position.
- With Soft Seat, Flexible Metal Seat & Fire Safe Seat are also available as per requirements.

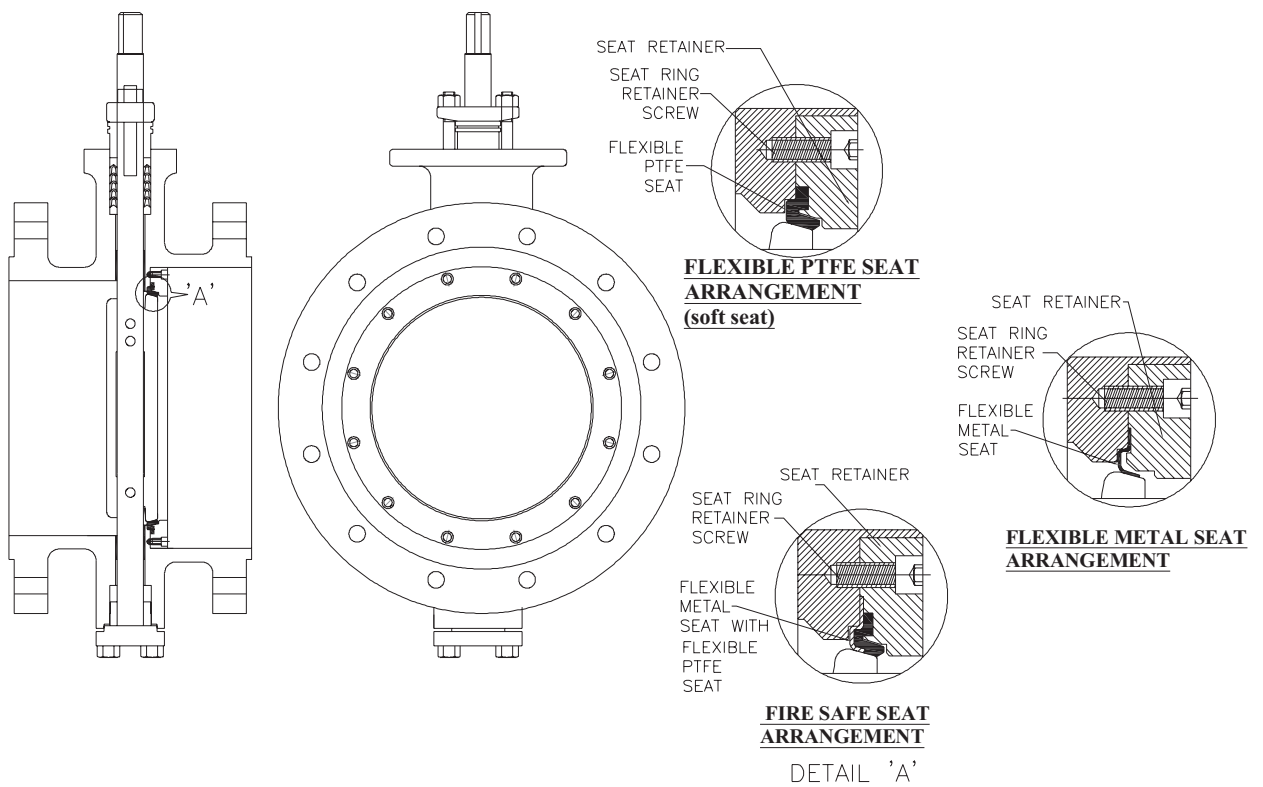

10.1 Replacing Guide Bush (Bearings)

- (1) Isolate the Control Valve from line pressure
And release the pressure.
- (2) Remove the complete Valve from the pipe line.
- (3) Remove Gland Packing refer. 9.0 to 9.6
- (4) Unscrew and remove the Seat Retainer Bolt.
- (5) Take out the Seat Retainer.
- (6) Take out Soft Seat .
- (7) Remove the Locking Pin from the Disc by slight hammering. (Upper & Lower)
- (8) Remove Front Shaft.(Disc should be Supported)
- (9) Loosen and remove Bottom Cover Bolt.
- (10) Remove Bottom Cover.
- (11) Remove Rear Shaft.
- (12) Remove Disc properly.
- (13) Keep the Disc in a safe place away from dust and scratches.
- (14) Now slowly remove the Guide Bush by slightly hammering by a pusher tool avoiding scratches in the Valve Body.
- (15) Replace the Guide Bush with new one.
- (16) Insert the Disc in the Valve Body and maintain its position
- (17) Insert Rear Shaft from bottom side.
- (18) Install Bottom Connection & Bolt it.
- (19) Insert Lock Pin in Rear Shaft and Disc properly by slight hammering.
- (20) Insert Front Shaft from top.
- (21) Insert Lock Pin in Front Shaft and Disc properly by slight hammering.
- (22) Install Gland Packing refer. 9.0 to 9.6
- (23) Place the Soft Seat followed by Seat Retainer along with its clamping screws.
- (24) Tighten the Seat Retainer clamping screws.
- (25) The Valve is ready to be placed in the pipeline.

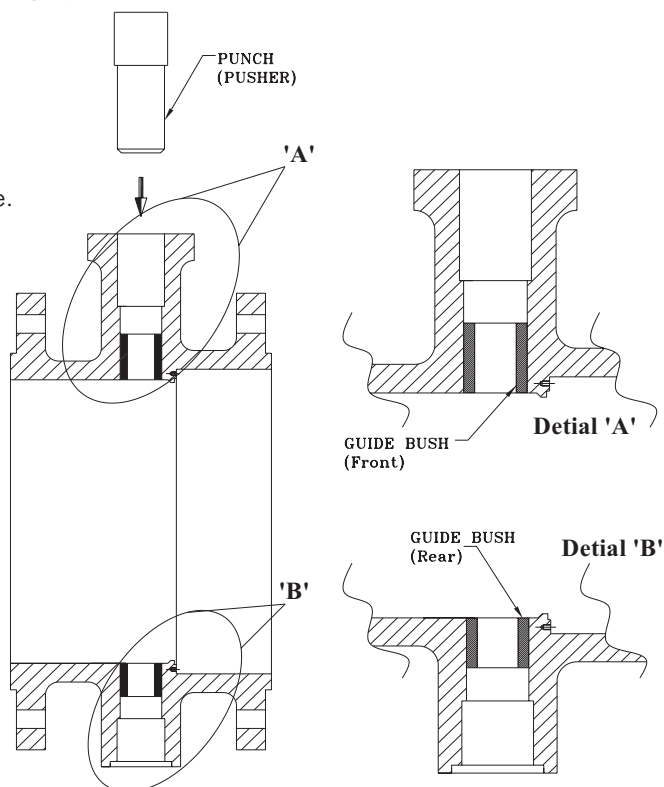

10.2 Trouble Shooting

Sr. No.	Condition	Possible Cause	Corrective Action
1	Gland Leakage	Gland Nut loose	Adjust Gland Nut
		Worn out Packing	Replace Gland Packing
2	Seat Leakage	Limit stop for Closed position stop got disturbed	Adjust limit stop of Gear operator
		Sealing edge of Seat damaged	Replace Soft Seat
		Valve pressurized to high pressure	Reduce line pressure to rated pressure
		Fluid is abrasive and eroding away the components	Replace the worn out component of valve with material suitable for abrasive media
3	Valve does not Open / Close fully	Limit stop got disturbed	Adjust limit stop
		Foreign object got stuck up between Disc and Seat	Open the Valve and clean the line / Valve to remove foreign object
		Disc to shaft connection failed	Replace Disc Pins and/or Shaft
4	Opening / Closing torque excessive	Excessive dirt accumulated at the components	Clean the components
		Shaft , Bearings or seat worn out	Replace the worn out components

11.0 Hand Lever Type Manual Operator

Series 'H' Hand Lever arrangement provides latching system in open, closed and other eight equally spaced intermediate positions. A pointer indicates the position of disc and an additional lock facility is provided to prevent unauthorized Valve operation. Lever operators are provided on Size 2" (50mm) to 6" (150mm) only. For Size 8" (200mm) and above, Gear Box Type Operators are Recommended.

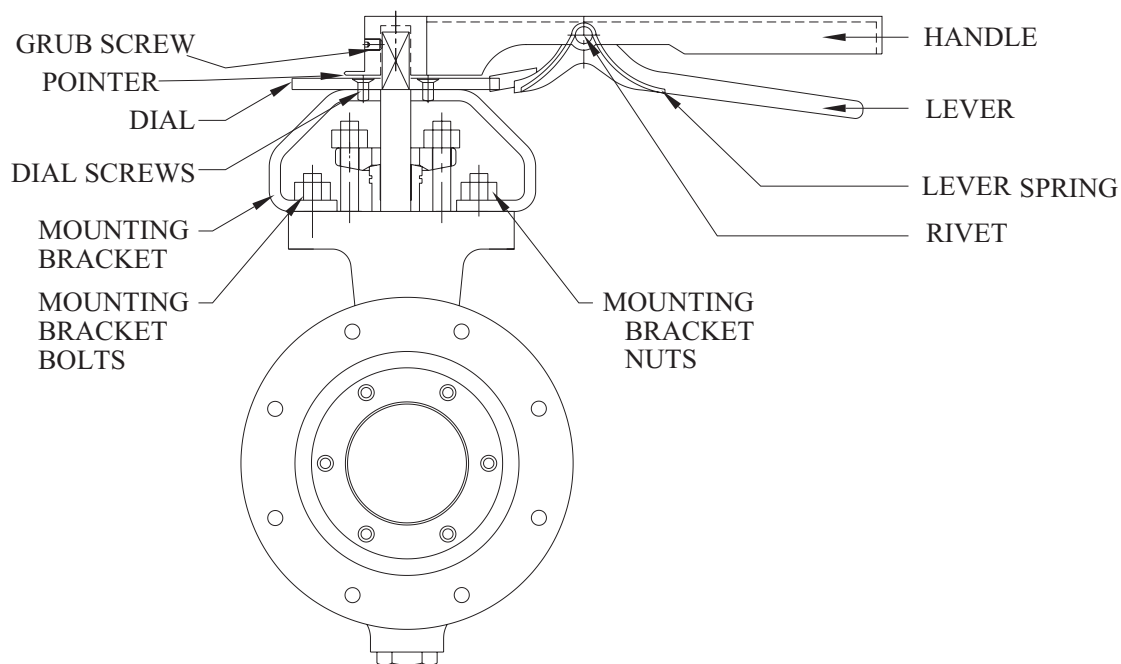

11.1 Operation

To operate the Hand Lever, hold the handle and squeeze the Lever to compress the Lever Spring. This is done to dis-engage the Lever from previously held position. Now rotate the handle slowly with the compressed Lever Spring position to the required Valve position and release the Lever in the slot or notch provided in the Dial.



- **Handle should be moved slowly to close the Disc of the Valve. Sudden closing may cause pipeline pressure to surge and may risk damage to the equipment / person's life.**
- **Before releasing the lever, check that the Lever is positioned and engaged in the slot / notch provided in the Dial. If the Lever is not engaged then the pipeline pressure can cause the Lever to rotate and hence Valve will close suddenly and pipeline pressure may surge, risking damage to the equipment /person's life.**

11.2 Removing Hand Lever Operator from the Valve Body



Pipeline pressure while removing the operator may cause the Valve to close suddenly and pipeline pressure may surge, risking damage to the equipment / person's life. To avoid this, drain the flow and release the pipeline pressure before removing the operator.

- (1) Drain the flow and release the pipeline pressure.
- (2) Close the Valve.
- (3) Loosen the Grub Screw.
- (4) unscrew the Mounting Bracket Bolts which is connected to Valve Body.
- (5) Remove the hand Lever operator from the Valve Body along with the Mounting Bracket.
- (6) To assemble follow the reverse sequence.

12.0 Gear Box Type Manual Operator

Series 'MOR' quarter turn Gear operators offer simple and reliable Manual positioning of the Butterfly Valves for 0 to 90° operation. These operators consist of single stage worm and worm wheel arrangement housed in a robust weather-proof cast iron housing. Adjustable mechanical stoppers are provided to the operator within $\pm 5\%$ of the extreme positions. A mechanical position Indicator is provided on these units to show the Valve position. Units are grease filled in the factory and does not require further lubrication. Thrust bearings provided takes axial thrust in operation. Sturdy design provides long life and maintenance free services. The high Gear ratios enable the minimum input efforts for high torque conditions.

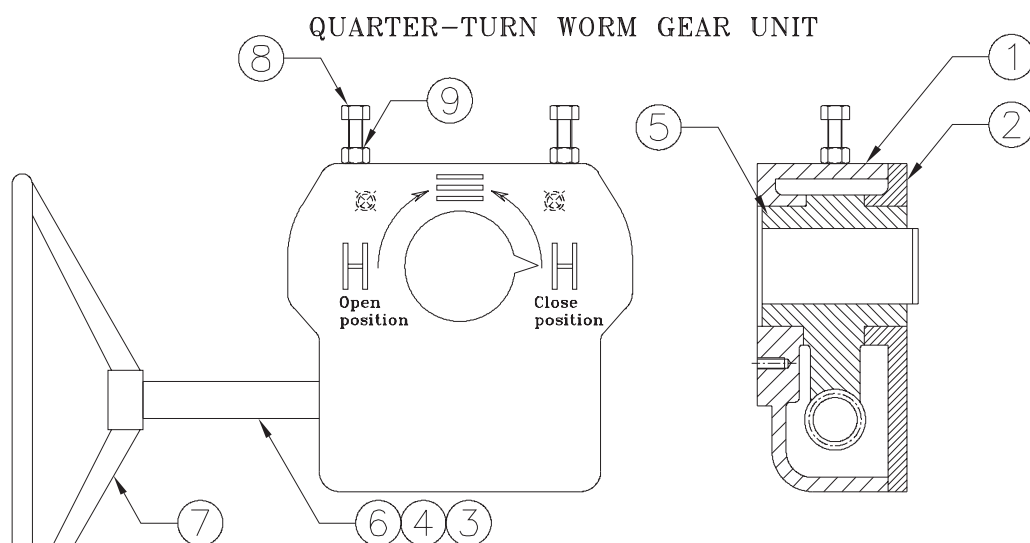

SR NO.	Q.T.Y.	DESCRIPTION	MATERIAL
1	1	MAIN HOUSING	CI GR.FG 260
2	1	COVER	CI GR.FG 260
3	1	INPUT SHAFT	En8
4	1	WORM	En8
5	1	WORM WHEEL	S.G.IRON
6	2	THRUST BEARING	STD
7	1	HAND WHEEL	M.S.
8	2	STOPPER	M.S.
9	2	LOCK NUT	M.S.

DRG No.2

12.1 Operation

To close the Valve, Rotate Gear operator handwheel clockwise.

To open the Valve, Rotate Gear operator handwheel anti-clockwise.

12.2 Setting of Gear Box Type Operator

The Open and Closed position stops prevent the operator from rotating beyond the open and closed position of the Valve respectively. Each stop is adjustable. If the operator is factory-mounted on the Valve, the stops are preset, and do not require any further adjustment.

If the operator is not factory mounted on the Valve, or if the operator has been removed, the stop will require adjustment as described below.

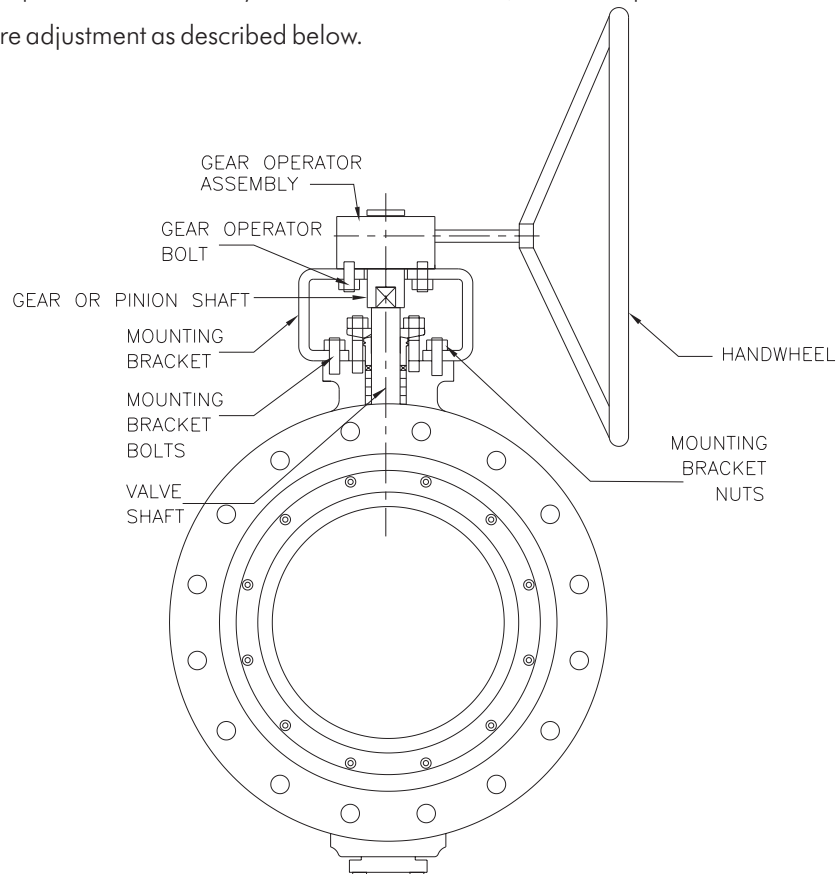

To adjust closed position stop : (Refer Drg.No.2)

- (1) Loosen the Lock Nut by rotating it anti-clockwise on closed position stop screw (stopper) to about 2 turns.
- (2) Turn the hand wheel so that the Valve is in the closed position.
- (3) Turn the Closed position stop screw (stopper) clockwise until it touches the Gear inside of the operator.
- (4) Hold the Closed position stop screw (stopper) head from turning, and tighten the Lock Nut by rotating it clockwise.

To adjust the Open position stop: (Refer Drg.No.2)

- (1) Loosen the lock nut by rotating it anti-clockwise on Open position stop screw (stopper) to about 2 turns.
- (2) Turn the Hand Wheel so that the Valve is in the open position.
- (3) Turn the Open position stop screw (stopper) clockwise until it touches the Gear inside of the operator.
- (4) Hold the Open position stop screw (stopper) head from turning, and tighten the Lock Nut by rotating it clockwise.

13.0 Installation of Manual Operator

13.1 Fixing / Mounting Hand Lever on Body Set

- (1) Insert the Mounting Bracket in the Shaft.
- (2) Align the Hand Lever on the top of the Valve Shaft by using Lever slot exactly sit in the Valve Shaft square provided.
- (3) Insert and then tighten the Grub Screw to fix up the Hand Lever with the Valve Shaft.
- (4) Tighten the Dial Screw.
- (5) Place Lever operator and Valve in closed position.
- (6) Mount the Mounting Brackets on the Valve Body by the using Mounting Bracket Bolts.
- (7) Check Open and closed positions of the Hand Lever without the flow and pressure.

13.2 Fixing / Mounting Gear Box Type Operator on Body Set

- (1) Fix up the Pinion Shaft with Gear operator by using Key.
- (2) Place the Gear operator along with the Pinion Shaft on the Mounting Bracket.
- (3) Align & fix the Valve Shaft with Pinion Shaft accurately.
- (4) Fix the Gear operator with Bracket by using Bolts.
- (5) Fix the Gear operator along with Mounting Bracket by using Bolts on Valve Body.

14.0 Parts Illustrated

14.1 Butterfly Valve Assembly Flange Type: - SIZE 2 (50mm) TO 6 (150mm)

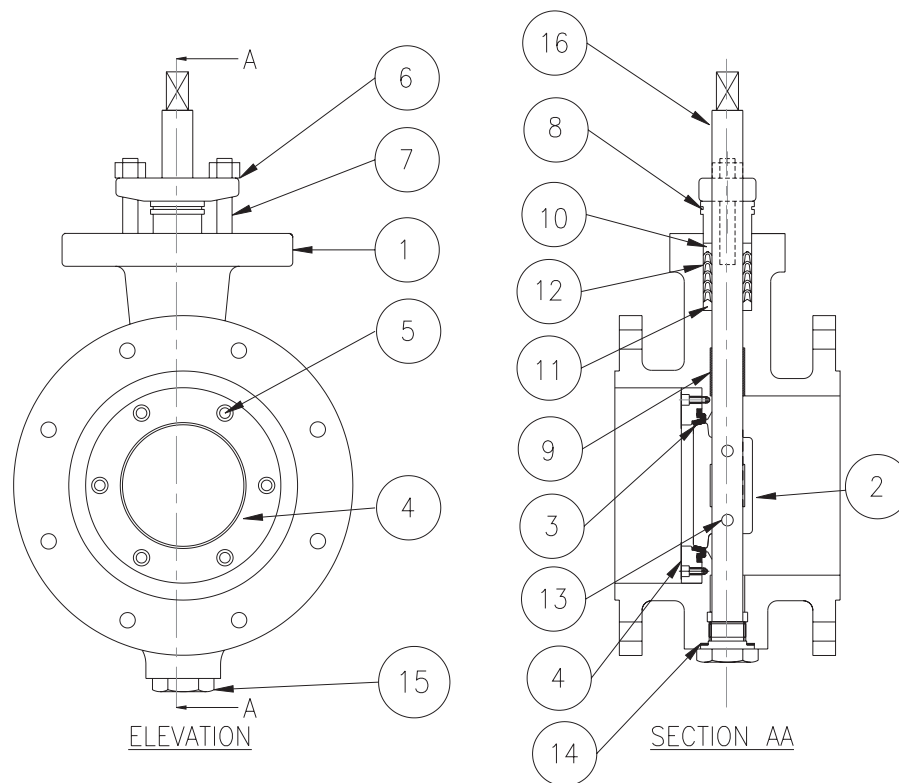

No.	PART	QTY.
1	BODY	1
2	DISC	1
3	SOFT SEAT	1
4	SEAT RETAINER	1
5	ALLEN BOLT	1 set
6	GLAND FLANGE	1
7	GLAND STUD / NUT	2
8	GLAND BUSH	1
9	GUIDE BUSH . (BEARING)	1 set
10	PACKING SPREADER- FRONT	1
11	PACKING SPLENDOR - REAR	1
12	GLAND PACKING.	1 set
13	DISC LOCKING PIN.	2
14	GASKET - BODY TO BOTTOM COVER.	1
15	END COVER	1
16	VALVE SHAFT	1

14.2 Butterfly Valve Assembly Flange Type: - SIZE 8 (200mm) & 72 (1800mm)

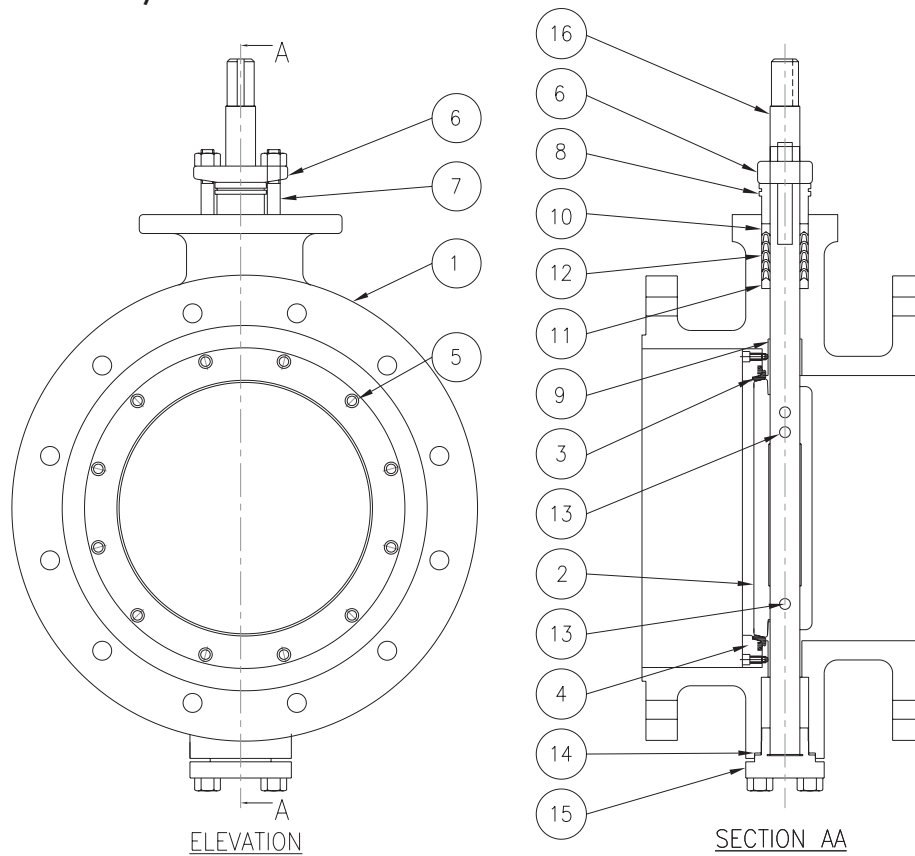

No.	PART	QTY.
1	BODY	1
2	DISC	1
3	SOFT SEAT	1
4	SEAT RETAINER	1
5	ALLEN BOLT	1 SET
6	GLAND FLANGE	1
7	GLAND STUD / NUT	2
8	GLAND BUSH	1
9	GUIDE BUSH . (BEARING)	1 SET
10	PACKING SPREADOR- FRONT	1
11	PACKING SPREADOR - REAR	1
12	GLAND PACKING.	1 SET.
13	DISC LOCKING PIN.	3
14	GASKET - BODY TO BOTTOM COVER.	1
15	END COVER	1
16	VALVE SHAFT	1

15.0 Torque For Studs

Studs	Torque Nm
5/16"	5
3/8"	7
1/2"	30
5/8"	50
3/4"	170

16.0 Recommended Spare Parts

It is recommended to stock following Spare Parts for commissioning and routine service:

No.	PART NAME	RECOMMENDED QUANTITY
3	Soft Seat	One for every Five identical or One minimum.
9	Guide Bush	One set for every Five identical or One set minimum. (front & rear)
12	Gland Packing	One Set for every Two identical or One Set minimum.

Note

While Ordering Spares, Please do not miss to indicate 'Valve Serial No.' appearing on Nameplate provided on the operator Yoke or on Valve Body Flange. The Valve Serial No. begins with alphabet 'V' followed by numbers, for e.g. V-12345....

The contents of this publication are presented for informational purposes only, and while every effort has been made to ensure their accuracy. They are not to be construed as warranties or guarantees, express or implied, regarding the products or services described herein or their use or applicability. We reserve the right to modify or improve the designs or specifications of such products at any time without notice. Dembla does not assume responsibility for the selection, use or maintenance of any product. Responsibility for proper selection, use and maintenance of any Dembla product remains solely with the purchaser and end-user.

Valve Disposal Detail : After the complete use of valve. Dispose the valve with accessories as per your local laws.



Dembla

Sales Office:

M/S. Dembla Valves Ltd.
C-30, Jai Matadi Compound, Kalher
Village, Thane-Bhiwandi-Agra Raod -
421302,
Maharashtra, India.
Tel - +91-9292234790 - 97
E-mail - expo@dembla.com
More info - www.dembla.com

Works:

M/S. Dembla Valves Ltd.
A/8, Arahm Logistic, Valshind Village,
Mumbai -Nashik Highway
(NH3), Bhiwandi
Thane - 421302. Maharashtra (India)