



Dembla

Instruction Manual

Globe 3 Way Valve

Series-3000



1Feb 2009



CONTENTS		PAGE NO.
1.0	Foreword	2
1.1	Scope of Instruction Manual	2
1.2	Copyright and Modification Rights Reservation	2
2.0	Storage & Preservation	2
3.0	Valve Marking	3
4.0	Health & Safety	4
5.0	Unpacking	5
6.0	Lifting Details	6
7.0	Installation	7
8.0	Maintenance	9
8.1	Removing Actuator from Valve Body	9
Fig.2	Direct & Reserve Acting Actuator	10
Fig.3	Various Gland Packing Arrangement	11
8.2	Packing Maintenance	12
9.0	Replacing Gland Packing	12
9.1	V-PTFE Packing	13
9.2	Double V-PTFE Packing	13
9.3	Grafoil Packing	14
9.4	Double Grafoil Packing	14
9.5	V-PTFE Low Fugitive Emission Packing	15
9.6	Grafoil Low Fugitive Emission Packing	15
Fig.4	Trim Combination	16
10.0	Trim Maintenance	17
10.1	Disassembly	17
10.2	Assembly	18
Fig.5	Direct Acting Actuator	19
10.3	Lapping Procedure	19
11.0	Reassembly of Actuator on Valve Body	20
11.1	Direct Acting Actuator	20
11.2	Reserve Acting Actuator	20
12.0	Trouble Shooting	21
13.0	Torque for Studs	21
14.0	Recommended Spares	21
15.0	Part Illustrated	22

1.0 Foreword

1.1 Scope of Instruction Manual

This Instruction Manual covers information regarding Installation and Maintenance of Dembla's Globe 3 Way Valves, Series 3000.

No person may install, operate or maintain Dembla Valve without 1) being fully trained and qualified in Valve, Actuator and Accessory Installation, operation and Maintenance 2) Carefully reading and understanding the contents of this Manual. If you have any questions about these Instructions contact Your Dembla Sales Office before proceeding.

1.2 Copyrights and Modification Rights Reservation

Dembla Valves Ltd. retains the Copyright on the contents of this Instruction Manual. The total content of this Instruction Manual described here corresponds to the Information during preparation of the Instruction Manual. It is user's responsibility to refer the latest version.

All data, specifications and illustrations here are subjected to Technical Modifications and improvements and hence Modification can be done by us at any time without any prior notice. No claim to Modification or repair of these Valves, which have already been supplied by us, can be made.

2.0 Storage & Preservation

All Valves are dispatched in the closed/open position as ordered and it is recommended that they are left in this position during storage. All protective packing should remain in position until the Valve is to be Installed.

Valve should be stored in a clean and dry environment, without disturbing company setting. (e.g. Gland, Seat etc.) Protect it from shock & lifting damage.



If hoisting the valve, use a nylon sling to protect the surface. Carefully position the sling to prevent damage to Actuator tubing and any Accessory. Also, take care to prevent people from being injured in case the hoist or rigging slips unexpectedly. For Valve Weight refer Valve Packing Slip.

3.0 Valve Marking

- 1) Valve name plate attached on Valve by riveting carrying all Valve Identification Information.
- 2) Markings like Valve Size, Rating, Material etc. are as cast on Valve Bodies.
- 3) Valve Serial no. punched on Valve Body Flange for Valve Traceability.
- 4) If the product is not CE marked, then Name plate also without CE mark.

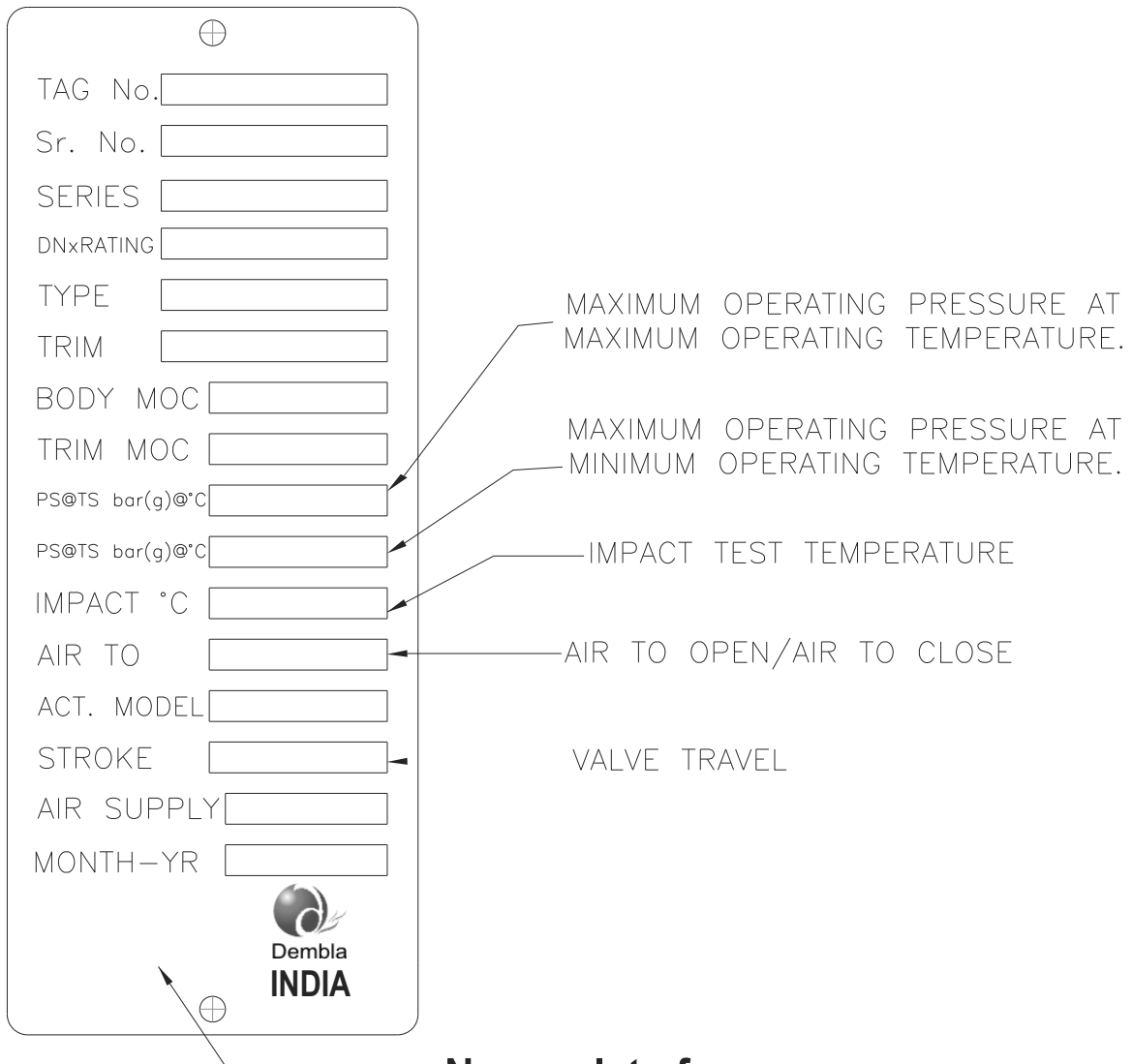

**Name plate for
Series:-3000 Valves**



4.0 Health & Safety

Warning

- 1) Before attending to Valve Installation / Maintenance, the Instruction Manual must be compulsorily read and understood properly.
- 2) Valve must be operated by qualified personnel.
- 3) Ensure that the operator handling these Valves must follow Safety and Accident Prevention Rules and Regulations.
- 4) Follow the Safety Instructions before Installation, Maintenance or removing the Valve.
- 5) Always wear protective gloves, clothing and eyewear when performing any Installation operations to avoid personal injury.
- 6) All Safety Messages such as Cautions, Warnings and Notes are highlighted in this Instruction Manual which must be strictly followed to avoid any possibility of arising danger / risk of damage to the equipment / person's life
- 7) No Liability on Manufacturer for any wrong handling, improper commissioning and wrong assembly.
- 8) Line must be fully drained and de-pressurized before Installation or Maintenance of Valve.
- 9) Never handle Valves that have been used on harmful substances unless they have been completely decontaminated and certified safe to handle.
- 10) Due to the large physical Size and weight of some Size of this product, always use correct lifting methods and equipment when Installing , removing and maintaining the product:
Use lifting lugs on the Body, wherever provided.
Valve without lifting lugs-use chains or slings wrapped around the Body.
Do not attempt to lift the Valve using the Sealant Fittings, Gear unit, Hand Wheel, Actuator, or the Valve Stem.
- 11) If the processes or environments that the products are used in are likely to cause change in temperature (high or low) that may cause injury to person if touched, then adequate insulation / protection must be fitted.
It is recommended that the insulation allows easy access for maintenance, to the Sealant Fittings, and to the Valve operator.
- 12) Valve must be protected from earthquake loading, traffic & wind.
- 13) No Modification / Conversions are allowed without written authorization from Dembla Valves Ltd.



Dembla

5.0 Unpacking

For Carton

- Keep Carton in position (Carton up side should not be down).
- Cut plastic strip properly which is tied around Carton & remove it. (White in colour).
- Cut cello tape properly which is stuck on Carton opening.
- Open Carton properly.
- Remove foam properly along with polythene wrapping.
- Lift the Valve properly & keep on clean & dry place

For Wooden Box

- Keep Wooden Box in Position (upside of Wooden Box should not be down).
- Cut iron strip properly which is tied around Wooden box & remove it.
- Remove nail properly from top cover with proper equipment.
- Loosen and remove Valve fixing nut (from inside of Box).
- Lift the Valve properly as shown in figure 1

6.0 Lifting Details

Valve should be lifted by using chain (Take care that Valve should not damage while handling).
or bearer cables as shown in figure 1.

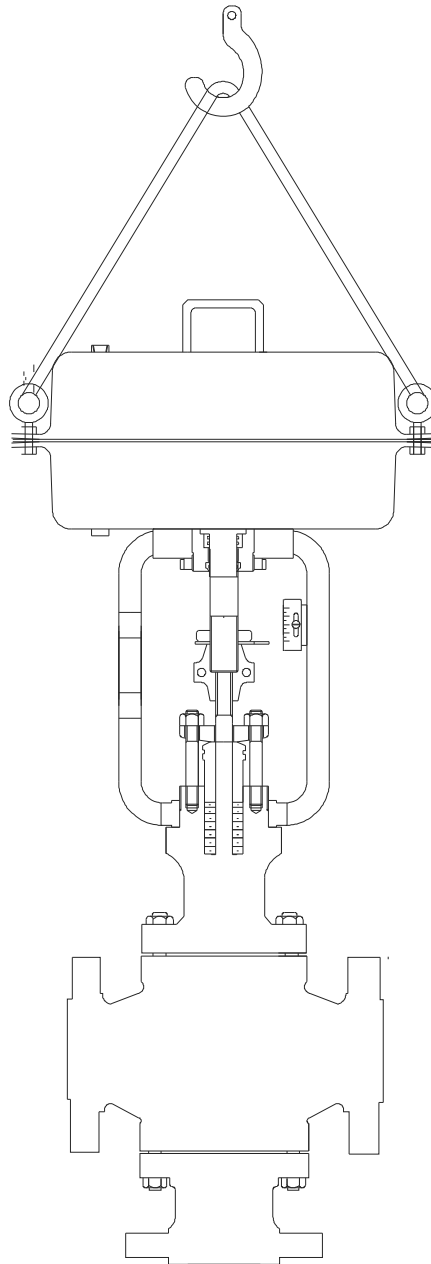

Fig. 1

7.0 Installation

Warning

- The Valve configuration & material of construction were selected to meet particular pressure, temperature, pressure drop and controlled fluid condition. Since the Body and trim material combinations are limited in their pressure drop and temperature ranges, hence do not apply any other condition to the Valve without first contacting, Dembla Valves Sales Office or Sales Representative.
- Before installing WELDING END Bodies, having soft seating arrangements, remove the trim to avoid damage to soft parts from the heat generated by welding.
- Connect the Valve in pipe line with the standard connections.
- Valve should not be used for dead end service.
- Before installing any Control Valve please check the following. :-
 - 1) Inspect it for any shipment damage and for any foreign material that might have been collected during Packing & shipment.
 - 2) Blow out all pipe lines to remove pipe scale, chips, welding, slag & other foreign material.
 - 3) Before installing the Valve make sure that pipeline flow is in the same direction as the arrow on the side of the Valve.
 - 4) Install the Control Valve preferably in a straight run of pipe away from bends or sections of abnormal velocity.
 - 5) Control Valves can be installed in any orientation but the normal method is with the Actuator Vertical. Should the need arise to install the Valve in other positions, adequate supports must be given to Yoke.
 - 6) If continuous operation is required during Maintenance and Inspection, a conventional three-way Valve by pass should be Installed.
 - 7) Install the Valve using accepted piping practices. For Flanged Bodies use a suitable Gasket between the Body and pipe line Flanges and tighten the Bolts evenly to avoid any strain on the Body or cracking of Flange.
 - 8) An air supply pressure regulator with filter should be installed in the air line ahead of any instrument on the Valve.

Warning

Rise in temperature on surface of Valve Body depend on working media. End user must be maintaining the surface temperature & it should not go beyond marking temperature on Valve (Name Plate).



Dembla

 **Warning**

- Always wear protective gloves, clothing, and eye ware when performing any Installation operation to avoid personal injury.
- Valve should be used by End-user with same pressure & temperature rating which was given in Valve Marking (Name Plate) If there is any change please contact Dembla Sales Office.
- Avoid personal injury or property damage caused by components dropping .With the Valve or Actuator upside, components may drop during disassembly or assembly. Be careful not to position yourself below the Valve in the path of falling parts.
- Personal injury could result from Packing Leakage. Valve Packing was tightened prior to shipment, but should there be any Gland Leakage after Installation, further tightening, just enough to stop Gland Leak is required. Excessive tightening will disturb Valve Calibration.
- Earthing facility must be provided by the end user before operating the Valve.
- Equipment should not be used for dead end service.

After the Valve has been Installed, make a final check of the following :-

- 1) An occasional cleaning of Valve Stem will prevent dirt or grit being carried away into the Packing.
- 2) Vary air lines and fitting to the Actuator to ascertain Actual Travel Scale Indication.
- 3) Check all air lines and fitting to the Valve Actuator & Accessories for air leaks.
- 4) Ensure that the combined action of Controller, Positioner and Valve provide the desired Valve Stem Movement. Also ensure the required fail safe position of Control Valve.

 **Caution**

- In case of Leak, presence of high temperature may be dangerous to the person's life.
- Equipment to be used as per intended and not misused / improperly used to avoid dangerous effects such as over load ,over heating ,stress corrosion cracking, etc.



8.0 Maintenance

Warning

- Avoid personal injury or damage to process system from sudden release of pressure of process fluid.
- Before starting dis-assembly Use by-pass Valve or completely shut off the process to isolate the Valve from process pressure. Drain fluid from both ends of the Valve.
- Disconnect all operating lines providing air pressure, electric power or a Control Signal to the Actuator.
- Earthing facility and Valve parts should be checked periodically by the end user.
- Any Gasket once removed should be replaced by a new one upon Re-assembly. This is necessary to ensure a good Seal since the used Gasket may not seal properly.
- Equipment should be cleaned regularly.

8.1 Removing Actuator from Valve Body

Note

The Valve Plug must be off the seat while the Stem Connector is being removed.

Please Refer Fig. No. 2.

- 1) Release Spring Compression.
- 2) Loosen the travel Indicator Lock Nut.
- 3) Unscrew the Allen Bolts of Stem Connector take off the two halves of Stem Connector.
- 4) Unscrew the Yoke Locking Ring (Part Ring) & remove it out of Bonnet.
- 5) Lift the Actuator Assembly over the Valve Stem, off the Valve, taking care to avoid damaging any Valve part or accessories attached to it.



Dembla

DIRECT ACTING ACTUATOR

REVERSE ACTING ACTUATOR

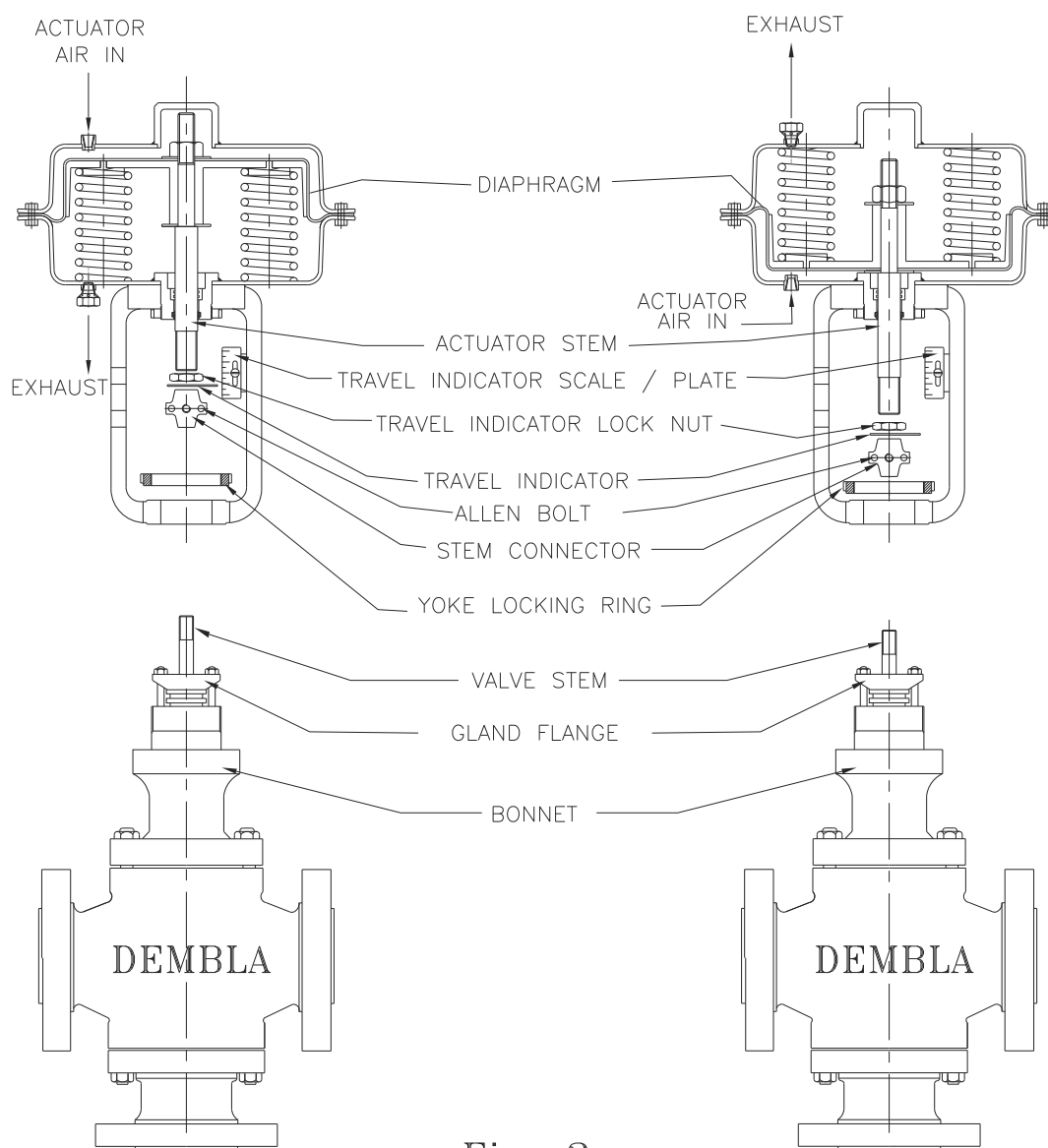
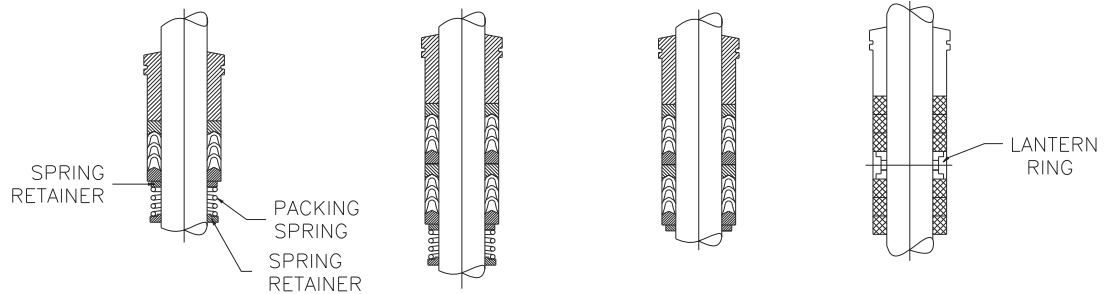

Fig. 2



VARIOUS GLAND PACKING ARRANGEMENTS



SINGLE V-PTFE WITH SPRING

DOUBLE V-PTFE WITH SPRING

DOUBLE V-PTFE WITHOUT SPRING

DOUBLE BRAIDED RINGS

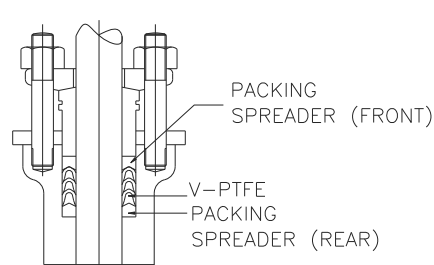

V-PTFE WITHOUT SPRING

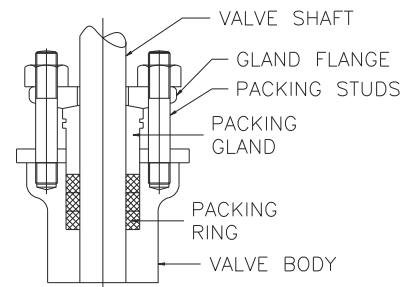

BRAIDED RINGS

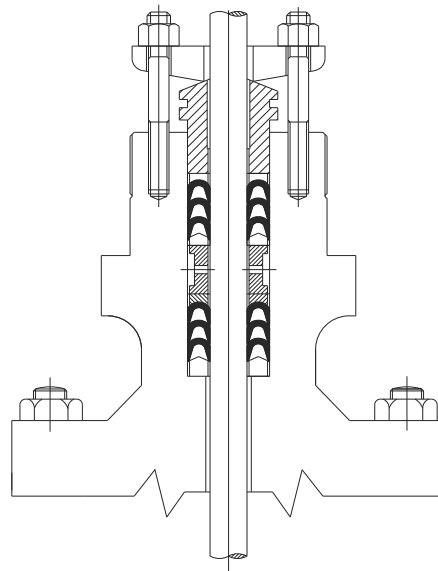

FIG.3

8.2. Packing Maintenance

For Packing arrangement, please refer to Fig. 3.

If there is undesirable Packing Leakage tight the Gland Flange nuts just enough to stop Gland Leakage. If Leakage cannot be stopped in this manner, proceed to Section 9.0 Replacing Gland Packing . Do not tight the Packing excessively, this may disturb the Valve Calibration.

9.0 Replacing Gland Packing

- 1) Isolate the Control Valve from line pressure & release the pressure.
- 2) Remove Actuator from Valve Body as shown in section 8.1 Removing Actuator from the Valve Body.
- 3) Remove the Nuts from Body Studs on Bonnet and lift the Bonnet carefully off the Body. If the Valve Plug & Stem assembly starts to lift along with Bonnet, use a brass or Nylon hammer on the end of the Stem & tap it back down.



Caution

Set the Bonnet on a protective surface to prevent damage to the Bonnet Gasket surface.

- 4) Remove the Valve Plug & Stem assembly from the Body.
Handle the Plug & Stem carefully to avoid the damage at seating surface of & stem diameter.
- 5) Unscrew and remove Gland Flange Nut.
- 6) Remove Gland Flange.
- 7) Push out Gland Packing from the Bonnets bottom side Gland Packing& Spreader carefully take out by using a rounded rod or other tool that will not scratch but clean the stuffing box wall.
- 8) Install Plug & Stem assembly. Then slide the Bonnet over the stem and on to the Body Studs.
- 9) Install new Packing Seal & Metal Gland parts according to the appropriate arrangement.
- 10) Lubricate the Body Studs and install the nuts. Use accepted bolting procedure during tightening so that the Body to Bonnet joint will with stand test pressures and application service condition, before tightening Nuts make sure that Plug & Stem assembly is properly aligned with Seat Ring.
- 11) For the Installation of Gland Packing refer following 9.1 to 9.6
- 12) Mount the Actuator & Connect Stem Connector as specified in the Reassembly of Actuator on Valve Body Refer Section 11.0 of this Manual.

9.1 V-PTFE Packing

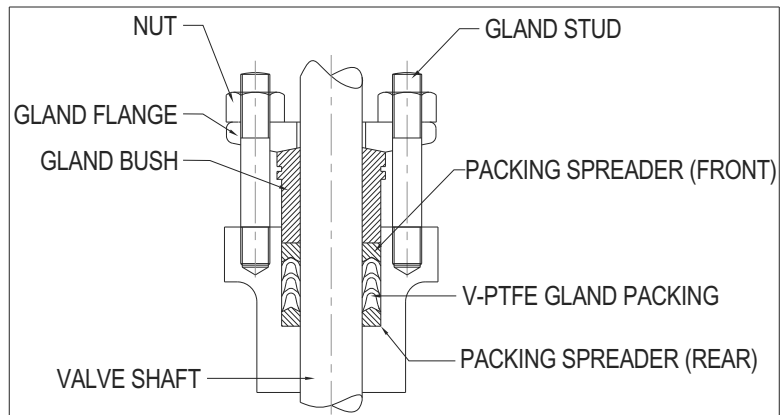

This Gland Packing consists of 1 Rear Packing Spreader, 1 set of V-PTFE Gland Packing and 1 Front Packing Spreader.

- (1) Place the V-PTFE Gland Packing set in the Body after 1 Rear Packing Spreader followed by Front Packing Spreader as shown in Fig. 9.1 Lubrication is not required.



Caution

Push each V-PTFE Packing carefully inside to avoid the Packing lip to bend towards the outer side.

- (2) Insert the Gland Bush.
- (3) Insert the Gland Flange on Gland Studs and tighten their Nuts to specified torque.

9.2 Double V-PTFE Packing

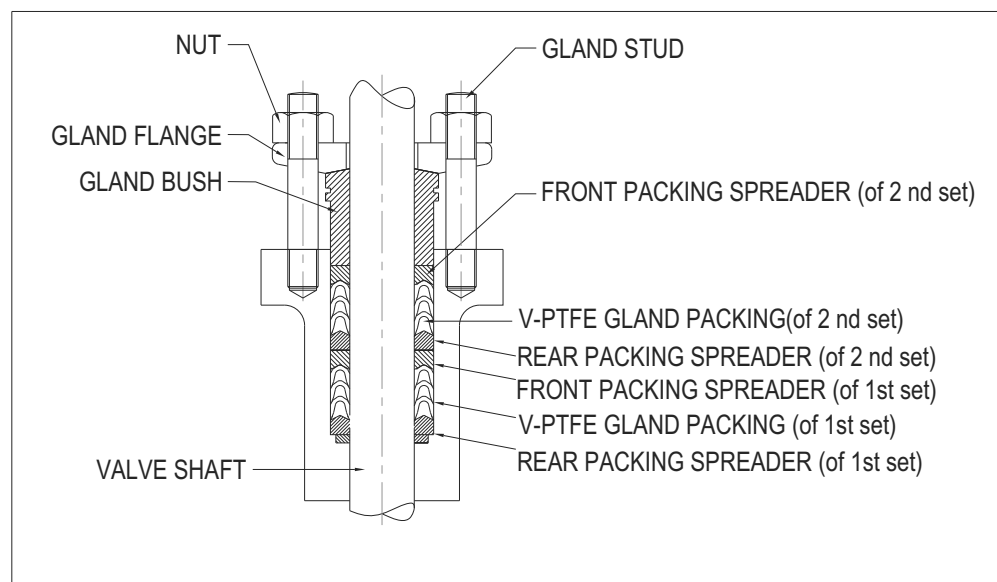



This Gland Packing consists of 1st set of Front and Rear Packing Spreader, 1st set of V-PTFE Gland Packing, 2nd set of Front and Rear Packing Spreader & 2nd set of V-PTFE Gland Packing.

- 1) Place the 1st set of V-PTFE Gland Packing after Rear Packing Spreader of 1st set followed by the Front Packing Spreader of 1st set.
- 2) On the Front Packing Spreader of 1st set place the 2nd set of V-PTFE Gland Packing after Rear Packing Spreader of 2nd set followed by the Front Packing Spreader of 2nd set.
- 3) Insert the Gland Bush.
- 4) Insert the Gland Flange on Gland Stud and tighten their nuts to specified torque.

9.3 Grafoil Packing

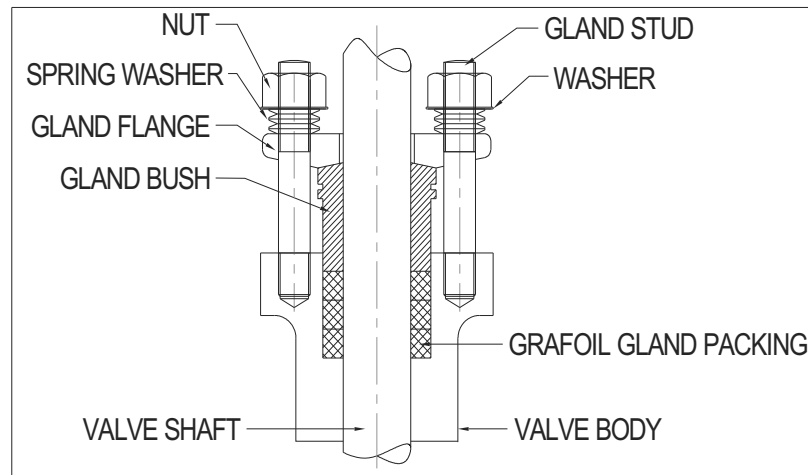

9.4 Double Grafoil Packing

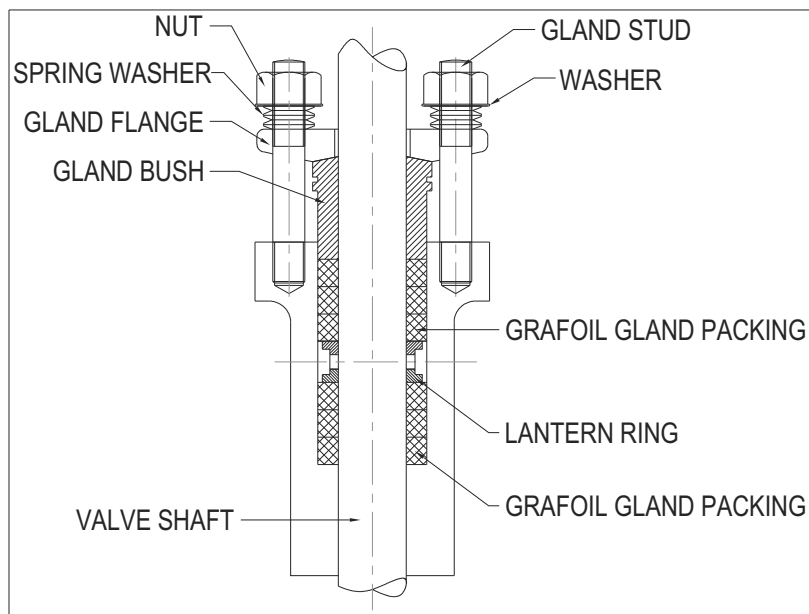



9.5 V-PTFE Low Fugitive Emission Packing

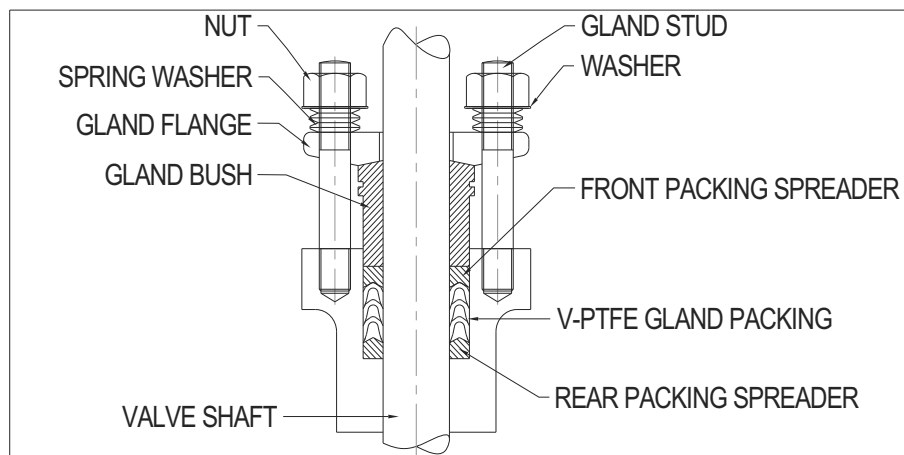

This Gland Packing consists of 1 Rear Packing Spreader, 1 set of V-PTFE Low Fugitive Emission Packing and 1 Front Packing Spreader.

- (1) Place the V-PTFE Low Fugitive Emission Packing set in the Body after 1 Rear Packing Spreader followed by Front Packing Spreader as shown in Fig. 9.5 Lubrication is not required.



Caution

Push each V-PTFE Packing carefully inside to avoid the Packing lip to bend towards the outer side.

- (2) Insert the Gland Bush.
- (3) Insert Gland Flange on Gland Studs.
- (4) Insert Spring washer on Gland Studs.
- (5) Insert Washer on Gland Studs.
- (6) Insert and tighten Gland nuts. (refer 9.5)

9.6 Grafoil Low Fugitive Emission Packing

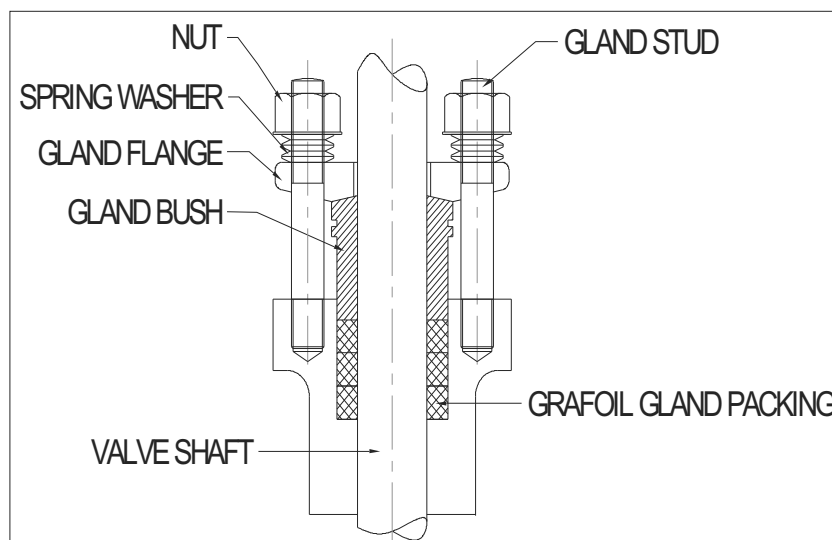



Trim Combination

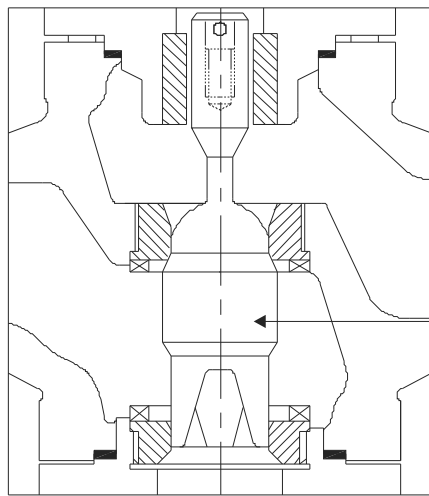

Metal to Metal Seating
Seat Leakage
Class:- IV & V

Plug

Contoured, Skirt & Top Bush Guide

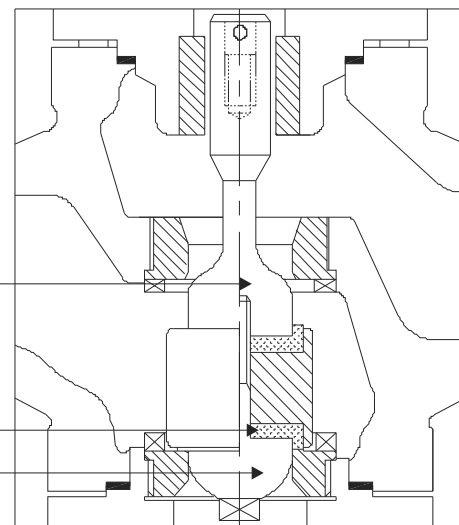

Metal to Soft Facing
Seat Leakage
Class:- VI

Plug Shank

Soft Seat

Nose

Contoured, Top Bush Guide (Soft Seated)

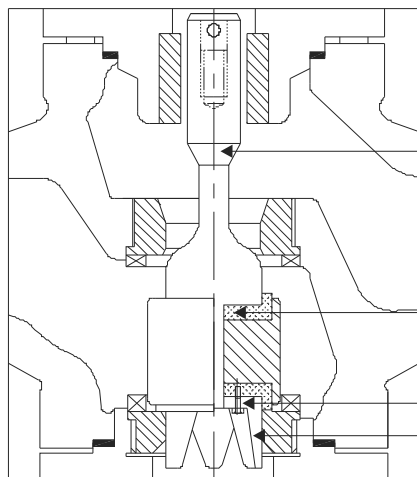

Plug Shank

Soft Seat

Bolt
Nose

Metal to Soft Facing
Seat Leakage
Class:- VI

Contoured, Skirt & Top Bush Guide (Soft Seated)

Fig.4

10.0 Trim Maintenance.

10.1 Disassembly

- 1) Isolate the Control Valve from line pressure & release the pressure from the Valve.
- 2) Remove Actuator from Valve Body as shown in Section 8.1 Removing Actuator from Valve Body .
- 3) Remove the Nuts from Body Studs on Bonnets end and lift the Bonnet carefully from the Body. If the Valve Plug & Stem assembly starts to lift along with Bonnet, use a brass or Nylon hammer on the end of the Stem & tap it back down.

For Trim arrangement please refer Fig. No. 4.



Avoid damaging Gasket Seating surface. The surface finish of the Valve Stem is critical for making a good Packing seal. Handle these parts carefully.

- 4) If required remove Gland Packing. (Refer. 9.0 to 9.6)
- 5) Remove Nuts from Bottom Connection Studs.
- 6) Remove Bottom Connection with the Seat Ring. (Lower Seat Ring)
- 7) Remove Seat Ring from Bottom Connection if required. (Lower Seat Ring)
- 8) Remove Stem with the Plug from Valve.(from bottom side)
- 9) Drive out the Locking Pin and unscrew the Stem from Plug.
- 10) If required replace Plug / Stem with new one. (From Dembla valves)
- 11) Unscrew and remove the Seat should it require machining or replacement.(Upper Seat Ring)
- 12) Use reverse sequence for Plug and Stem assembly.
- 13) Keep all part on clean and dry space properly.

For Soft Seated Plug Disassembly (Refer fig. 4)

- 1) Plug below 4 :-
 - i) Hold Plug- Shank than unscrew Plug nose and remove it.
 - ii) Remove Soft Facing if required.
 - iii)For assembly use reverse sequence.
- 2) Plug above 4 :-
 - i) Hold Plug Shank loosen and remove Plug Nose Bolts.
 - ii) Remove Plug Nose.
 - iii) Remove Soft Facing it required.
 - iv)For assembly use reverse sequence.

10.2 Assembly

- 1) Clear all Gaskets surface & use all new Gaskets for assembly.
- 2) Install Seat Rings in the Body& Bottom Connection.(Upper Seat Ring)
- 3) Install Seat Rings in the Body& Bottom Connection.(Lower Seat Ring)



If the Packing is to be re-used and was not removed from the Bonnet, use care when installing Bonnet to avoid damaging the Packing with the Valve Stem threads. However the stem threads are always truncated.

- 4) Insert the Gasket in the Body. (Body Bonnet Gasket).
- 5) Install Bonnet on the Body and Bolt it loosely.
- 6) Insert Plug & Stem assembly in the Body form Bottom Side of Valve. (Stem should insert in Bonnet).
- 7) Then slide the Bottom Connection over the Plug form Bottom Side and Bolt it loosely.
- 8) Before tightening the Bonnet and Bottom Connection Nuts make sure that Plug and Stem assembly is properly aligned with Seating.
- 9) Tighten the Bolt of Bottom Connection & Bonnet.
- 10) Install Gland Packing refer. 9.0 to 9.6
- 11) Lubricate the Body Studs & Install Nuts. Use accepted bolting procedure during tightening
- 12) Mount Actuator & Connect Stem Connector as specified in the section 11.0 Reassembly of Actuator on Valve Body.

DIRECT ACTING ACTUATOR

REVERSE ACTING ACTUATOR

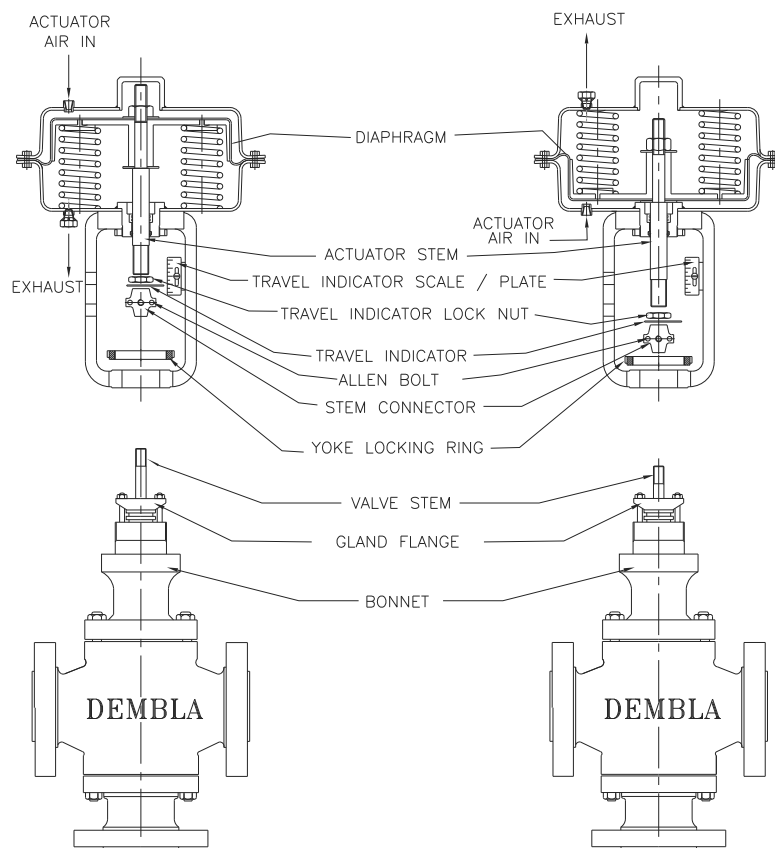

10.3 Lapping Procedure

- a) Produce a simple lapping tool. This can be made by welding a screwed Stud (having threading to match with Plug) to the center of a Hexagonal bar about one foot long. Screw and lock the tool to the end of the Plug.
- b) Apply lapping compound to the seating surface of the Seat Ring only. Lubricate the Plug Stem where it enters the Packing Box, with light oil.
- c) Lap with short oscillating strokes. The weight of the Plug, Stem and lapping tool provide ample pressure for lapping. Do not bear down.
- d) Raise the Plug occasionally, lower it to another position and resume the oscillating strokes. This ensures an even lap over the entire seating surface of Plug and Seat.
- e) Approximately 5 to 10 minutes lapping time is usually required to obtain a satisfactory fit between a new Plug and Seat.
- f) Clean the Plug and Seat. Holding the Plug on to the Seat by hand, apply compressed air to the inlet side of the Valve to check the tightness of the lapped parts. Repeat the lapping procedure, if necessary.
- g) Disassemble the Valve and clean all parts thoroughly. Remove all traces of lapping compound.

11.0 Re-assembly of Actuator on Valve Body.

11.1 Direct Acting Actuator

- 1) Lower the Actuator over the Valve Stem & Gland Flange to sit squarely on Bonnet shoulder.
- 2) Rotate the Actuator to the correct position. Keep the travel Indicator Plate on front side.
- 3) Screw the Yoke Ring into the Valve Bonnet threads and tighten it.
- 4) While the Actuator Stem be Connected to the Valve Stem, both the stem should be at their lowest position of travel. The Plug should be resting on its Seat. Apply air pressure to Actuator Diaphragm to bring Actuator Stem to lower position of Valve travel as indicated on travel scale. Press the two halves of Stem Connector against the Actuator Stem & Valve Stem.

Lock the Stem Connector screws in this position. Tight the Indicator Lock Nut against the top of Stem Connector.
- 5) Remove the air supply & check the travel once again on travel Indicator.

11.2 Reverse Acting Actuator

- 1) Mount the Actuator on the Valve Bonnet shoulder accordingly to the steps 1,2,& 3 of Re-assembly of Direct Acting Actuator.
- 2) While the Actuator Stem is to be connected to the Valve the Plug should rest on Seat & the Actuator Stem should be lifted by approx. 2-3 mm up ward, so that the diaphragm is not in contact with top of the Yoke. Apply little pressure to the Diaphragm so that the Actuator Stem lifts to 2-3 mm approximately. Push the Valve Stem downward so that Plug rests on the Seat Ring. Press two halves of Stem Connector against the Actuator Stem & Valve Stem. Lock the Stem Connector screw in the position. Lock the Indicator Lock Nut against the top of the Stem Connector.
- 3) Apply full air pressure to Diaphragm as indicated in the Tag Plate of the Valve so that the indicator reads 100% opening on travel scale. Remove air pressure & once again check the travel.



12.0 Trouble Shooting

No.	Condition	Possible Cause	Corrective Action
1	Gland Leakage	Gland Nut loose.	Adjust Gland Nut
		Worn out Packing.	Replace Gland Packing
2	Seat Leakage	Sealing edge of seat damaged	Replace Soft Seat
		Valve pressurized to high pressure	Reduce line pressure to rated pressure
		Fluid is abrasive and eroding away the components	Replace the worn out component of Valve with material suitable for abrasive media
3	Valve does not Open / Close fully	Foreign object got stuck up between Plug and Seat	Open the Valve and clean the line / Valve to remove foreign object
		Disturbed Calibration	Correct Calibration.
4	Opening / Closing torque excessive	Foreign object got stuck up between Plug and Seat	Open the Valve and clean the line / Valve to remove foreign object
		Extra Gland Nut tightening	Retighten the Gland Nuts.

13.0 Torque For Studs

Studs	Torque Nm
5/16	5
3/8	7
1/2	30
5/8	50
3/4	170

14.0 Recommended Spares

Each Body-Bonnet assembly is assigned with a series number which can be found on the Valve Flange O.D. This same number also appears on Actuator nameplate. While ordering spares please do not miss to indicate Valve Series No. The valve Sr. no Starts with Prefix V-12345.....

It is recommended to stock the following parts as spare for commission and routine service. Parts marked (*) have generally longer life. Hence are left to the choice of customer to include in their spares.

Sr. No.	PART NAME	RECOMMENDED QUANTITY
15	Gasket Body to Bonnet	One No. Per Unit
7	Gland Packing	One Set Per Unit
2	*Seat Rings (Upper & Lower)	Two set for Every Five identical or One set minimum.
3	*Valve Plug	One for Every Five identical or One minimum.
13	*Valve Stem	One for Every Five identical or One minimum.



Dembla

15.0 PARTS ILLUSTRATED

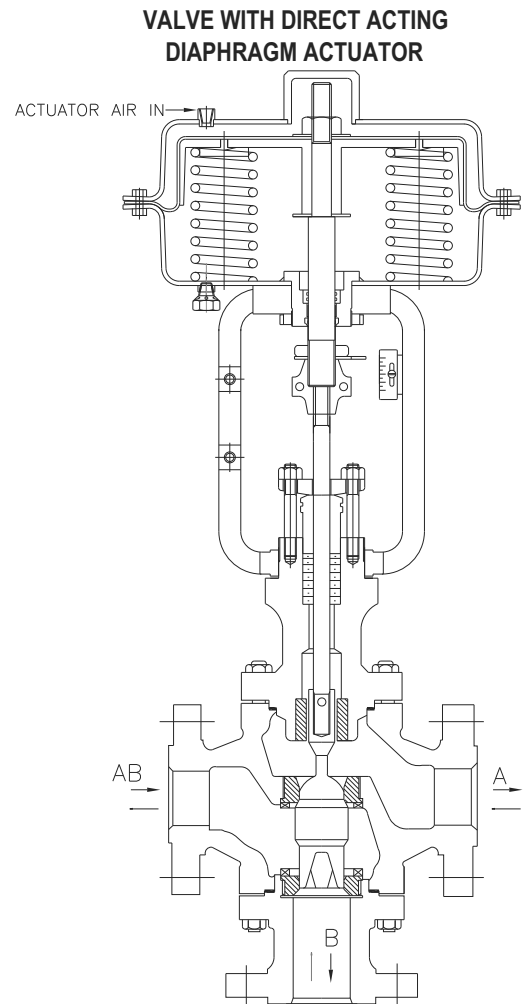
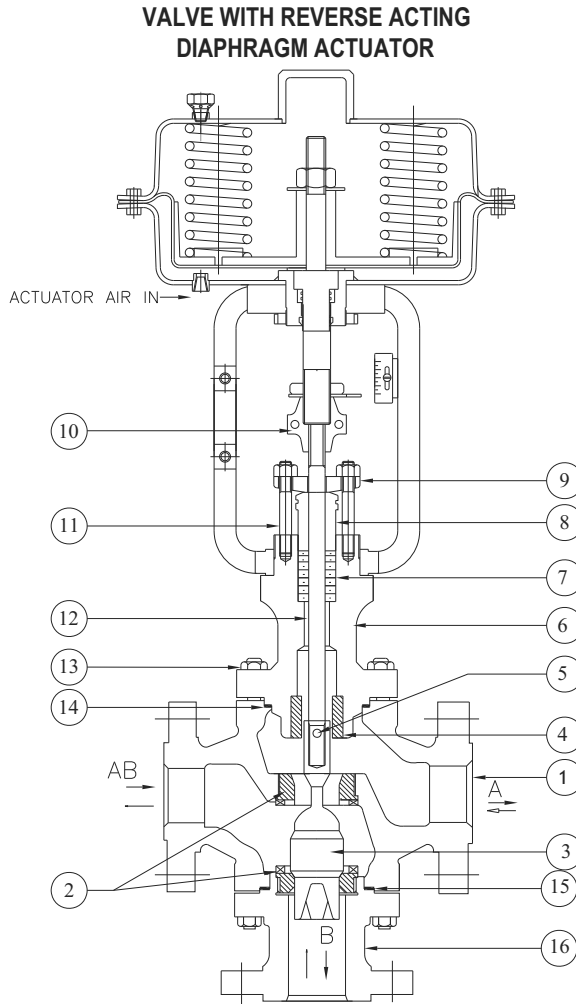

SR. NO.	PART NAME	SR. NO.	PART NAME
1	VALVE BODY	9	GLAND FLANGE
2	SEAT RING	10	STEM CONNECTOR
3	VALVE PLUG	11	PACKING STUDS/NUTS
4	GUIDE BUSH	13	VALVE STEM
5	LOCKING PIN	14	BODY STUDS/NUTS
6	BONNET	15	GASKET-BODY TO BONNET
7	GLAND PACKING	16	GASKET BODY TO BOTTOM CONN.
8	GLAND BUSH	17	BOTTOM CONNECTION

The contents of this publication are presented for informational purposes only, and while every effort has been made to ensure their accuracy. They are not to be construed as warranties or guarantees, express or implied, regarding the products or services described herein or their use or applicability. We reserve the right to modify or improve the designs or specifications of such products at any time without notice.

Dembla does not assume responsibility for the selection, use or maintenance of any product. Responsibility for proper selection, use and maintenance of any Dembla product remains solely with the purchaser and end-user.



SALES (INTERNATIONAL) OFFICE ADDRESS :
M/S Dembla Valves Ltd (Unit 2)

C-30, Jai Matadi Compound, Kalher Village
Thane-Bhiwandi-Agra Road-421302, Maharashtra, India.
Tel : 912522 275132 / 275184 / 275104 / 241700
Fax: 912522 275132 / 275184 / 275104
E-Mail: expo@dembla.com

SALES (DOMESTIC) OFFICE ADDRESS:
M/S Dembla Valves Ltd.

1-Adarsha Industrial Estate Pokhran Road No.1,
Upvan, Thane - 400 606 (Maharashtra), India.
Tel (O): 022 - 25858234/25853957/25853899
Fax: 022 - 25853429
E-Mail: info@dembla.com

REG. OFFICE & WORKS :

Unit 1 : Purna Village Thane - Bhiwandi - Agra Road, Dist : Thane - 421 302, Maharashtra, India
Unit 2 : C-30, Jai Matadi Compound, Kalher Village, Thane-Bhiwandi-Agra Road - 421302, Maharashtra, India